

MOROOKA MST 2200VD

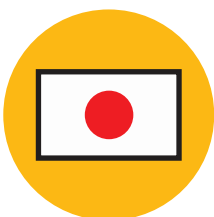

MADE IN JAPAN



PAYLOAD



CUMMINS DIESEL



TRACK WIDTH

Specifications

Make	Morooka
Model	MST 2200VD
Payload	11000kg
Unladen Weight	14100kg
Maximum Speed	10 KPH / 6.2 MPH
Engine Make & Model	Cummins QSB 6.7
Engine Type	6 cylinder liquid cooled diesel
Engine Power @ 2000rpm	186 KW / 249 HP
Ground Pressure Empty	33.2 KPA / 4.81 PSI
Ground Clearance	480 mm
Fuel Type	Diesel

MOROOKA

MST 2200VD

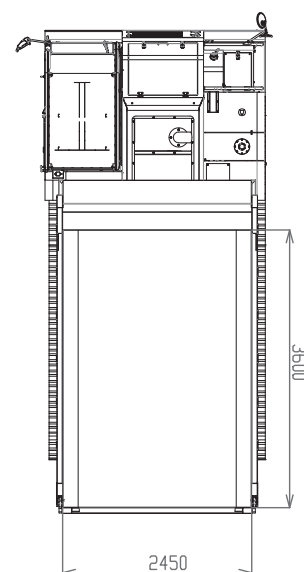
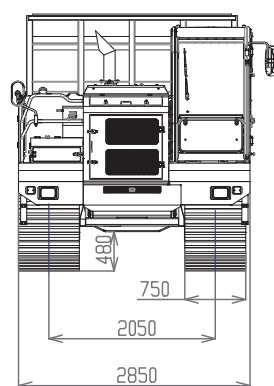
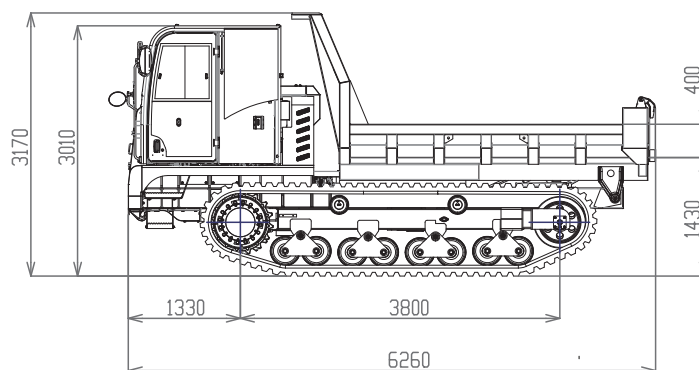

Dimensions

Overall Length	6260 mm
Overall Width	2850 mm
Overall Height	3170 mm
Track Centres	2050 mm
Track Width	750 mm
Dump Body Length Internal	3600 mm
Dump Body Width Internal	2450 mm

