

SPECIFICATIONS

*With rubber shoe type

Model		U27-4	
Machine weight	Cabin / Canopy	kg	2590 / 2490
Operating weight	Cabin / Canopy	kg	2665 / 2565
Bucket capacity, std. SAE/CECE		m ³	0.06
Bucket width	With side teeth	mm	500
	Without side teeth	mm	450
Model		D1105-E4-BH-2	
Type		Water-cooled, diesel engine E-TVCS (Economical, ecological type)	
Engine	Output ISO9249	PS/rpm	21.2 / 2400
		kW/rpm	15.6 / 2400
	Number of cylinders	3	
	Bore x Stroke	mm 72 x 78.4	
Displacement		cc 1123	
Overall length		mm 4190	
Overall height	Cabin	mm 2430	
	Canopy	mm 2420	
Swivelling speed		rpm 9.8	
Rubber shoe width		mm 300	
Tumbler distance		mm 1560	
Dozer size (width x height)		mm 1500 x 300	
Hydraulic pumps	P1, P2		Variable displacement pump
	Flow rate	ℓ /min	28.8 x 2
	Hydraulic pressure	MPa (kgf/cm ²)	21.6 (220)
	P3		Gear Type
Max. digging force	Flow rate	ℓ /min	19.2
	Hydraulic pressure	MPa (kgf/cm ²)	17.2 (175)
	Arm	kN (kgf)	12.3 (1260)
	Bucket	kN (kgf)	21.0 (2140)
Boom swing angle (left/right)		deg 75 / 55	
Auxiliary circuit	Flow rate	ℓ /min	48
	Hydraulic pressure	MPa (kgf/cm ²)	17.2 (175)
Hydraulic reservoir		ℓ 22	
Fuel tank capacity		ℓ 33	
Max. travelling speed	Low	km/h	2.5
	High	km/h	4.5
Ground contact pressure	Cabin	kPa (kgf/cm ²)	24.7 (0.25)
	Canopy	kPa (kgf/cm ²)	23.7 (0.24)
Ground clearance		mm 290	

*Machine weight: with 35kg standard bucket and fully served
*Operating weight: with 75kg operator, 35kg standard bucket and fully served

WORKING RANGE

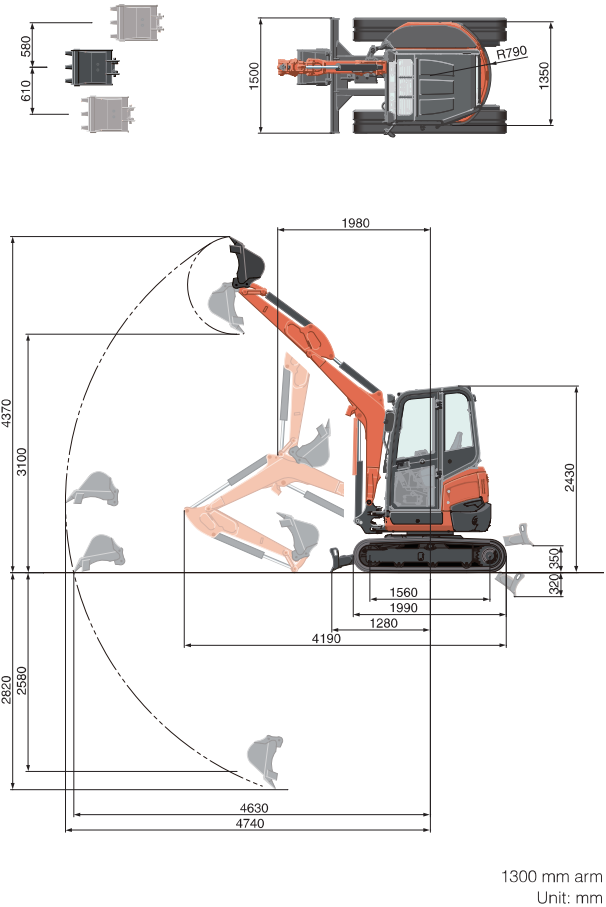

LIFTING CAPACITY

Lift Point Height	Lifting point radius (2m)		Lifting point radius (max.)	
	Over-front (blade down)	Over-side	Over-front (blade down)	Over-side
1.5m	7.3 (0.74)	7.2 (0.73)	-	-
1.0m	10.2 (1.04)	6.8 (0.69)	4.2 (0.43)	2.4 (0.25)
0.5m	11.5 (1.18)	6.5 (0.67)	-	-
0m	12.3 (1.25)	6.4 (0.66)	-	-

*The lifting capacities are based on ISO 10567 and do not exceed 75% of the static tilt load of the machine or 87% of the hydraulic lifting capacities of the machine.

**The excavator bucket, hook, sling and other lifting accessories are not included on this table.

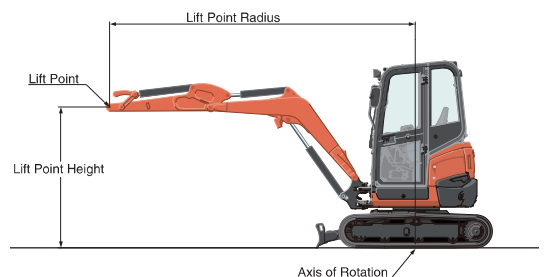

* Working ranges are with Kubota standard bucket, without quick coupler.
* Specifications are subject to change without notice for purpose of improvement.

★ All images shown are for brochure purposes only.
When operating the excavator, wear clothing and equipment in accordance to local legal and safety regulations.

KUBOTA EUROPE S.A.S.

19 à 25, Rue Jules - Vercurysse -
Zone Industrielle - B.P. 50088
95101 Argenteuil Cedex France
Téléphone : (33) 01 34 26 34 34
Télécopieur : (33) 01 34 26 34 99

KUBOTA (U.K.) LTD

Dormer Road, Thame, Oxfordshire,
OX93UN, U.K.
Phone : 01844-268140
F a x : 01844-216685

<http://www.kubota-global.net>

KUBOTA Baumaschinen GmbH

Steinhauser Straße 100
D-66482 Zweibrücken Germany
Telefon : (49) 0 63 32 - 487 - 312
F a x : (49) 0 63 32 - 487 - 101

Cat. No.8847-01-EU '14-03D.