

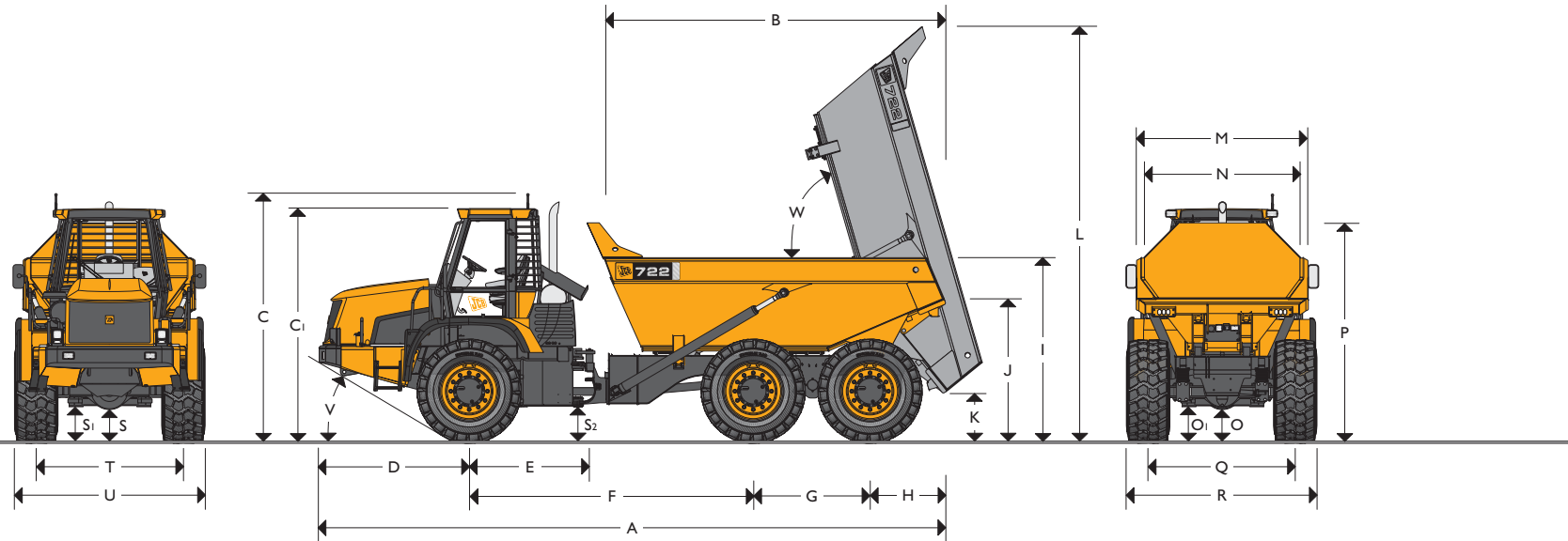

JCB ARTICULATED DUMP TRUCK | 722



MAX. OPERATING WEIGHT: 37.1 tonnes (81791lb)
 MAX. HORSEPOWER: 201 kW (270hp)



STATIC DIMENSIONS

	mm (ft-in)
A Overall length	9199 (30-2)
B Body length	5030 (16-6)
C Max. height	3446 (11-3)
C _i Height to top of cab	3310 (10-9)
D Front axle to front bumper	2174 (7-1)
E Front axle to pivot point	1575 (5-2)
F Wheelbase (front axle to intermediate axle)	4145 (13-9)
G Wheelbase (intermediate axle to rear axle)	1675 (5-5)
H Rear axle to rear of body	1105 (3-6)
I Height to top of body	2609 (8-6)
J Height to lip of body	2033 (6-7)
K Min. height to body when tipped	635 (2-0)
L Max. height to body when tipped	5947 (19-5)
M Max. external body width	2492 (8-2)

		mm (ft-in)
N Max. internal body width		2342 (7-7)
O Max. ground clearance (rear diff)		433 (1-4)
O _i Max. ground clearance (rear axle)		512 (1-7)
P Height to top of spill guard		3097 (10-2)
Q Wheel track (rear)		2122 (6-10)
R Overall width		2652 (8-7)
S Max. ground clearance (front diff)		433 (1-4)
S _i Max. ground clearance (front suspension arm)		373 (1-2)
S ₂ Ground clearance (pivot point)		420 (1-4)
T Wheel track (front)		2122 (6-10)
U Overall width		2652 (8-7)
V Departure angle (front)	degrees	30°
W Body tip angle	degrees	74°
Load capacity	tonnes (lb)	20 (44092)
Body – heaped	m ³ (yd ³)	12.0 (15.7)
Body – struck	m ³ (yd ³)	9.4 (12.3)

Overall dimensions based on an unladen machine equipped with Michelin 20.5 R25 XADN tyres.



JCB ARTICULATED DUMP TRUCK | 722



ENGINE

Type	6 cylinder direct injection diesel	
Model	QSB 6.7	
Capacity	litres (in ³)	6.7 (409)
Bore	mm (in)	107 (4.25)
Stroke	mm (in)	124 (4.75)
Aspiration	Turbo/charge cooled	
Cylinders	6	
Power rating		
Max power	kW (HP) @ 2200rpm	201 (270)
Gross power to SAE J1995/ISO 14396	kW (HP) @ 2400rpm	194 (260)
Net power to SAE J1349/EEC80/1269	kW (HP) @ 2400rpm	182 (242)
Torque rating		
Max. torque	Nm (lbf ft) @ 1500rpm	990 (730)
Net torque	Nm (lbf ft) @ 1500rpm	860 (634)

* Emissions Relevant standards US EPA Tier3 carb Tier 3, EU Stage IIIA (complies with EU / EPA "off highway" Construction Equipment Regulation Stage 2.)

TRANSMISSION

Transmission	Type	Smoothshift
	Make	ZF
Torque converter	Model	6WG2.10
	Type	Single stage
Torque converter ratio		1.773:1

AXLES

Type	Epicyclic hub reduction
Make and Model	ZF AP9
Overall axle ratio	21.85

TRAVEL SPEEDS

Assumes fitment of Michelin 20.5 R25 XADN		kph (mph)
Forward	First	5.51 (3.42)
	Second	8.58 (5.33)
	Third	13.69 (8.51)
	Fourth	21.36 (13.27)
	Fifth	32.45 (20.16)
	Sixth	46.0 (28.58)
Reverse	First	5.88 (3.65)
	Second	14.44 (8.97)
	Third	32.0 (19.88)

SUSPENSION

Type (front)	4-bar parallel link
Make	JCB
Type (rear)	Bogie beam suspension
Make	JCB

HYDRAULICS

Pump type	Variable displacement	
Pump: max flow @ 2200rpm	l/min (gal/min)	198 (52.3)
Pump: max pressure	bar (psi)	210 (3046)

SERVICE FILL CAPACITIES

	litres (UK gal)
Hydraulic system	174 (38.3)
Fuel tank	270 (59.4)
Engine oil sump	16.3 (3.58)
Transmission system	41 (10.8)
Axle oil (front)	29 (7.7)
Axle oil (intermediate)	29 (7.7)
Axle oil (rear)	29 (7.7)
Engine coolant system	33 (8.7)

ELECTRICAL SYSTEM

System voltage	Volt	24
Alternator output	Amp hour	70
Battery capacity	Amp hour	2 x 115

BODY

Tipping angle	degrees	74°
Body plate thickness (front)	mm (ft-in)	8 (0-03)
Body plate thickness (side)	mm (ft-in)	10 (0-03)
Body plate thickness (bottom/chute)	mm (ft-in)	10 (0-03)
Yield strength	N/mm ² (psi)	1000 (145000)
Tensile strength	N/mm ² (psi)	1250 (181000)
Hardness (min)	HB	400
Body raise (laden)	seconds	13
Body lower (unladen)	seconds	6
Scow angle	degrees	25



JCB ARTICULATED DUMP TRUCK | 722



STANDARD EQUIPMENT

Engine: 6 cylinder, common rail direct injection diesel engine. Wastegated turbocharger charged cooler for maximum torque and minimum exhaust smoke 3 stage dry type-cyclonic air cleaner with primary and safety elements. Stainless steel exhaust system, single bowl fuel filters. Complies to US EPA Tier 3, EU Stage 3 legislation.

Suspension: Front suspension is a four bar parallel link mechanism connected via a gas strut to a pre charged accumulator that dampens the vibration. The system is self-levelling whether laden or un-laden. The rear axles are pad mounted to a rocking beam mechanical suspension system.

Transmission: 6 forward and 3 reverse speed remote mount smoothshift transmission with integral lock up torque converter. Manual or automatic selection.

Axles: Pad mounted to the suspension. Limited Slip Differential in all axles. Planetary wheel hub reduction.

Steering: Double acting hydraulic system. Priority steer valve. Emergency steering via a ground driven pump.

Brakes: Dual circuit, hydraulic power dry disc type with braking on all six wheels. Electrically operated dry disc parking brakes on the driveline spring applied and hydraulically released. Brake disc guards.

Hydraulics: System comprising single variable displacement pump for priority steer, body tip and braking. Emergency steer via a ground driven pump.

Cab: ROPS and FOPS safety structure. Fully adjustable air suspension seat. Adjustable steering column. Air conditioning. Laminated safety glass. Electronic monitoring panel with LCD message display to include body up warning light. Front & rear screen wash / wipe. 3 speed heater / demisting with replaceable air filter. LH & RH opening doors. Single lever transmission selector. Single lever hydraulic tip control. Combination stalk controls for lights, wipers, horn, direction indicators. Separate side consul for auxiliary switches. Interior light, sun visor, external rear view mirrors, and operator's storage facilities.

Electrical: Road lights front and rear, front working lights, reversing alarm and light, rear fog lights, horn, battery isolator, beacon, radio fittings, 70 amp alternator.

Bodywork: Flexible front steps, non-slip walkways, recovery hitch, lifting lugs (rear body), engine access cover. Rear cab mounted spill guard. Cast 360 deg centre hitch.

Body: Constructed from high strength steel with large box section stiffeners and a high tensile steel floor. Large target area and load retention. Two single stage double acting cylinders located externally to the body.

OPTIONAL EQUIPMENT

Reversing camera; Heated seat and mirrors; Biodegradable hydraulic oil; 3" seat belt; Heated body; Fire extinguisher; 24-12 volt in cab converter.

OPERATING WEIGHTS

		Laden	Unladen
Front	tonnes (lb)	12.7 (27998)	8.7 (19180)
Rear	tonnes (lb)	24.4 (53791)	8.4 (18517)
Total	tonnes (lb)	37.1 (81791)	17.1 (37699)
Payload	tonnes (lb)	20.0 (44092)	-

Includes operator (80kg) and a full fuel tank.

TURNING CIRCLE

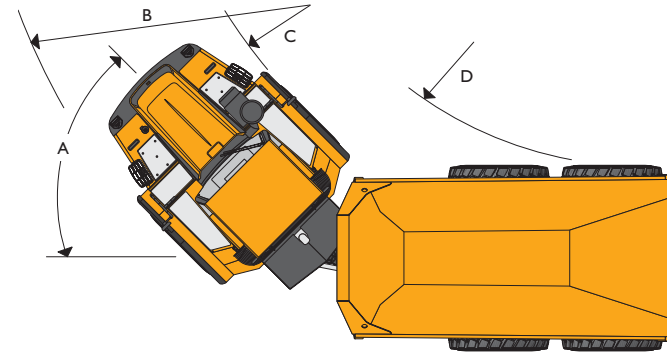

		mm (ft-in)
A	Articulation angle	degrees 45°
B	Clearance radius – over front tyres	9045 (29-7)
C	Turning radius (front unit)	7890 (25-9)
D	Turning radius (rear unit)	5340 (17-5)

CHANGES TO GROUND BEARING PRESSURES

Manufacturer	Tyre Size	Type	Laden		Unladen		Tyre Pressure	
			Front	Rear	Front	Rear	Front	Rear
			kPa (PSI)	kPa (PSI)	kPa (PSI)	kPa (PSI)	bar (PSI)	bar (PSI)
Michelin	20.5 R25	XADN	154 (22)	161 (23)	98 (14)	55 (8)	3.3 (48)	3.73 (54)
Michelin	650/65 R25	XAD	125 (18)	130 (19)	80 (12)	45 (7)	2.5 (36)	2.76 (40)
Goodyear	650/65 R25	GP-3D	118 (17)	125 (18)	78 (11)	49 (6)	2.8 (41)	3.1 (45)
Nokian	750/55-26.5	TRS LS-2	105 (15)	110 (116)	70 (10)	40 (6)	2.0 (29)	2.25 (33)
Trelleborg	850/45 B30.5	Twin 423 TL	90 (13)	95 (14)	60 (9)	35 (5)	2.4 (34)	2.2 (32)

Ground bearing pressure @ 15% sinkage.

CHANGES TO OPERATING DIMENSIONS

Manufacturer	Tyre Size	Type	Dimensional changes				Operating weight
			U	T	R	Q	
			mm (ft-in)	mm (ft-in)	mm (ft-in)	mm (ft-in)	
Michelin	20.5 R25	XADN	0	0	0	0	0
Michelin	650/65 R25	XAD	+126 (0-5)	+26 (0-1)	+126 (0-5)	+26 (0-1)	+900 (1980)
Goodyear	650/65 R25	GP-3D	+164 (0-6½)	+26 (0-1)	+164 (0-6½)	+26 (0-1)	+710 (1565)
Nokian	750/55-26.5	TRS LS-2	+328 (1-1)	+108 (4¼)	+328 (1-1)	108 (4¼)	-350 (770)
Trelleborg	850/45 B30.5	Twin 423 TL	+528 (1-9)	+208 (0-8)	+528 (1-9)	+208 (0-8)	-560 (1235)

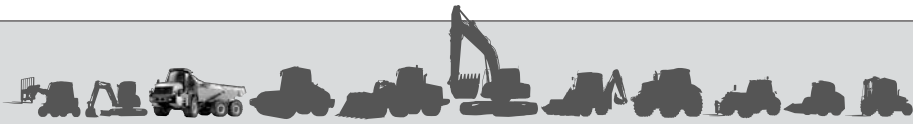

A GLOBAL COMMITMENT TO QUALITY

JCB's total commitment to its products and customers has helped it grow from a one-man business into Britain's largest privately owned manufacturer of backhoe loaders, crawler excavators, wheeled excavators, telescopic handlers, wheeled loaders, dump trucks, rough terrain fork lifts, industrial fork lifts, mini/midi excavators, skid steer loaders, tractors and compaction equipment.

By making constant and massive investments in the latest production technology, the JCB factories have become some of the most advanced in the world.

By leading the field in innovative research and design, extensive testing and stringent quality control, JCB machines have become renowned all over the world for performance, value and reliability.

And with a global sales and service network of more than 650 dealers and agents, we aim to deliver the best customer support in the industry.

Through setting the standards by which others are judged, JCB has become one of the world's most impressive success stories.

