

515-40 LOADALL



A Product of Hard Work



Innovation at its heart

At 1.8m, it's the ultimate,
go-anywhere, mini marvel

You want compact size and manoeuvrability. You want a machine that works in restricted height buildings. You want excellent lift height, lift capacity and reach. Before, all of this meant a combination of skid steer, wheeled loading shovel and forklift... not now. One machine, the JCB 515-40, ticks all the boxes, opening up telehandler versatility to a whole new range of users.

So how does the 515-40 do it? One word... innovation. Everything hinges on our revolutionary, off-set, single-spine chassis which has its core strength under the boom and wraps around the cab. This allows us to position the cab lower than usual providing three key benefits.

First, the whole machine is low, 1.8m in fact. Second, to achieve that height we haven't had to shrink the cab, as in some competitor machines, so there's no compromise on comfort or space. And third, cab entry is now at low level for improved health and safety.

Despite mini proportions, the 515-40 packs a real punch, in line with customer feedback which told us you want compact dimensions, with power. So this incredible innovation can lift 1.5 tonnes to 4m height, and 1 tonne across 2m for loading the opposite side of a truck.

Inside greenhouses, chicken sheds, tunnels and multi-storey car parks; craned into high-rise developments; a secondary site machine alongside your full-size Loadall; rental, builders' merchants, fruit farms, smallholdings, vineyards: the 515-40 is the mini marvel we've all been waiting for.

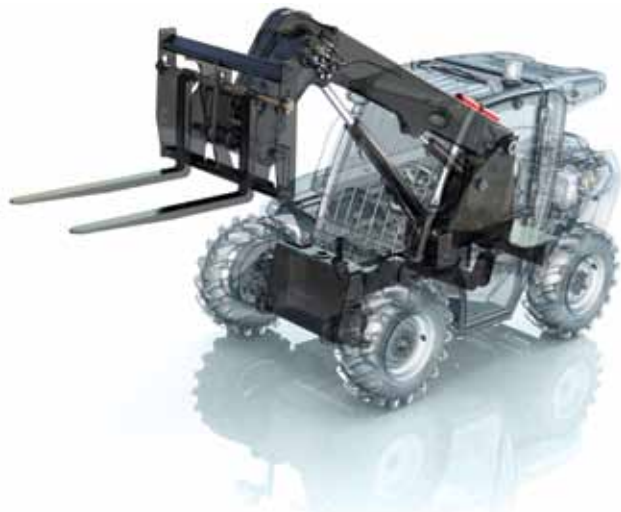



**You've got it into a tight space,
now what?**

**Incredible manoeuvrability,
performance and comfort...
that's what**

So, the 515-40 can get in where doorways or building height often prove an obstacle to other machines. The same is true of a skid steer, you say. Yes, but often a skid steer can't give access or loading height.

At the same time, the 515-40 gives shovel performance comparable to a skid steer or wheeled loading shovel. Plus, individual hydraulic wheel motors and four-wheel steer equals superb movement in the face of tight corners, pillars and narrow doorways.

Where ground conditions may vary, in builders' merchants or farmyards, for instance, four-wheel drive and good ground clearance more than copes with the challenging terrain. Add a hydrostatic transmission for easy operation, infinite speed variations and better fuel efficiency, and you have the winning formula for versatile performance and productivity.

The other feature that sets the 515-40 apart from its competitors is comfort. Thanks to the chassis design, there is no compromise on cab size to achieve the 1.8m height. So the interior is spacious with superb visibility.

The stable-type door allows you to shut out unpleasant conditions, or open up the top half for a little fresh air whilst still protecting the operator from mud and debris. Optional air conditioning or face level fan further enhance operator comfort. And the cab itself, with side, low-level entry, also means the 515-40 is a safer machine.





MAX. PAYLOAD: 1.5 tonnes (3307 lb) MAX. LIFT HEIGHT: 4 metres (13ft 1in) MAX. HORSEPOWER: 36.8 kW (50hp)

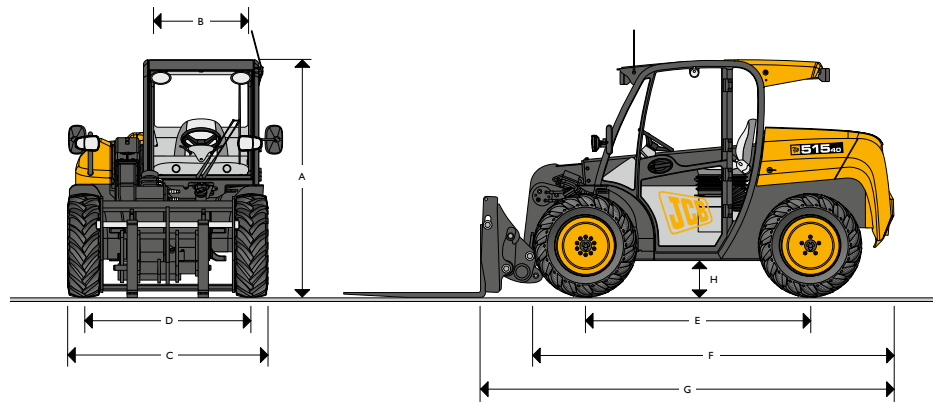

STATIC DIMENSIONS

| Machine model | 515-40 | |
|---------------------------------------|------------|--------------|
| A Overall height | m (ft-in) | 1.80 (5-11) |
| B Inside width of cab | m (ft-in) | 0.87 (2-10) |
| C Width over tyres | m (ft-in) | 1.56 (5-1) |
| D Front track | m (ft-in) | 1.30 (4-3) |
| E Wheel base | m (ft-in) | 1.75 (5-9) |
| F Overall length to front of tyres | m (ft-in) | 2.80 (9-2) |
| G Overall length to front of carriage | m (ft-in) | 3.23 (10-7) |
| H Ground clearance | m (ft-in) | 0.24 (0-10) |
| Outer turn radius over tyres | m (ft-in) | 2.80 (9-2) |
| Weight | kg (lb) | 3480 (7672) |
| Tyres | traction | 255/75-15.3 |
| | industrial | 10.0/75-15.3 |
| | semi-turf | 10.0/75-15.3 |

LIFT PERFORMANCE

| Machine Model | | Compact Loadall Quickhitch | Skid Steer Quickhitch |
|--------------------------------|------------|----------------------------|-----------------------|
| | | 515-40 | 515-40 |
| Lift capacity at full height | kg (lb) | 1500 (3307) | 1500 (3307) |
| Lift capacity at full reach | kg (lb) | 750 (1653) | 750 (1653) |
| Payload at 2.0m boom extension | kg (lb) | 1000 (2205) | 1000 (2205) |
| Max. lift height | mm (ft-in) | 4045 (13-3) | 4060 (13-4) |
| Reach at max. lift height | mm (ft-in) | 460 (1-6) | 380 (1-3) |
| Maximum reach forward | mm (ft-in) | 2535 (8-4) | 2455 (8-6) |

LIFT PERFORMANCE

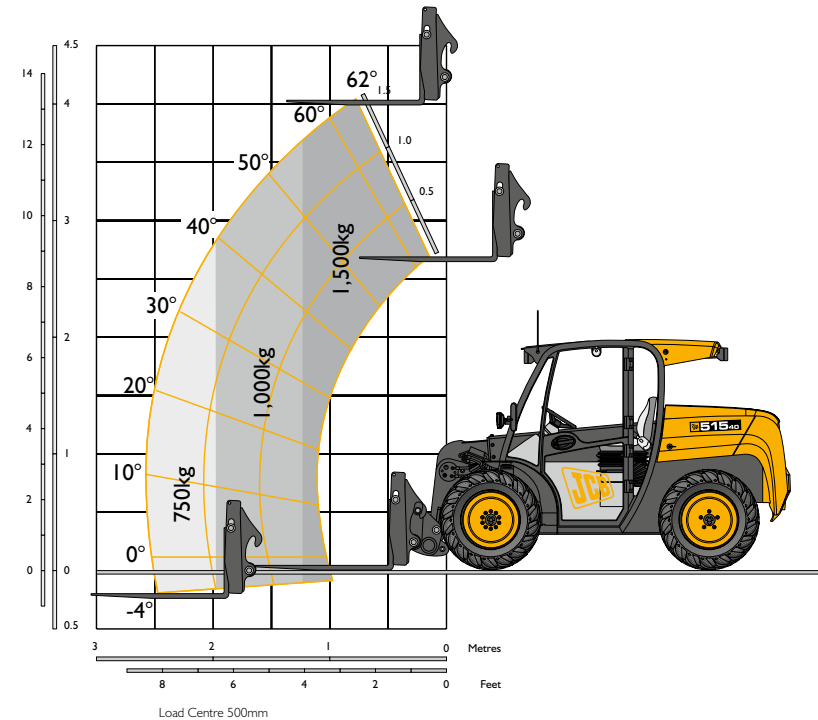

LOADER PERFORMANCE

| Machine Model | | Compact Loadall Quickhitch | Skid Steer Quickhitch |
|---------------------------------|-----------------------------------|----------------------------|-----------------------|
| | | 515-40 | 515-40 |
| Shovel rated capacity | m ³ (ft ³) | 0.48 (17) | 0.37 (13) |
| Breakout force | kgf (lb) | 3368 (7425) | 3569 (7868) |
| Dump height (max) | mm (ft-in) | 3662 (12-0) | 3663 (12-0) |
| Dump angle at max height | degrees | 30 | 35 |
| Loadover height (max) | mm (ft-in) | 4045 (13-3) | 4015 (13-2) |
| Rollback angle at ground | degrees | 35 | 30 |
| Carriage rotation angle (total) | degrees | 131 | 131 |
| Standard bucket width | mm (ft-in) | *1620 (5-4) | *1720 (5-7) |

* Other sizes available



ENGINE

| | | 515-40 |
|--------------------------------|------------|------------------------------|
| Model | | Deutz D2009L04 |
| Displacement | litres | 2.3 |
| Fuel | | Diesel |
| Cooling | | Liquid |
| Bore | mm (in) | 90 (3.5) |
| Stroke | mm (in) | 90 (3.5) |
| Gross power @ 2800 rpm | | |
| ISO 14396 | kW (hp) | 36.8 (50) |
| Gross torque @ 1800 rpm | | |
| ISO 14396 | Nm (lb/ft) | 146 (107.68) |
| Emission certification | | EC Stage IIIA/USA EPA Tier 3 |
| Engine oil service intervals | | 500 hours |

TRANSMISSION

Hydrostatic transmission.

Closed loop variable displacement piston pump with twin displacement transmission wheel motors.

Transmission inching facility on operation of a combined inching and braking pedal.

Front and rear drive axles: Permanent 4WS and 4WD.

- Rear axle oscillation.
- Automatic torque transfer system between front and back axles.
- Maximum travel speed 20kph (12.4mph).

BRAKES

Service brake: Hydraulically activated, drum brake on the front wheel motors.

Parking brake: Manually operated drum brake on the front wheel motors.

BOOM AND CARRIAGE

Boom is manufactured from high tensile steel.

Low maintenance, hard wearing pads.

JCB tool carrier parallel lift carriage with manual pin locking, accepts forkframe with integral pallet forks and a wide range of attachments.

Compact Tool Carrier: Compact Loadall compatibility.

Skid Steer Tool Carrier: Skid steer universal compatibility hitch.

SERVICE CAPACITIES

| | | litres (UK gal) |
|----------------|--|-----------------|
| Fuel tank | | 50 (11) |
| Hydraulic tank | | 38 (8.4) |

ELECTRICS

12 V negative earth, 60 AH heavy-duty battery. 80 amp alternator.

HYDRAULICS

| Machine model | | 515-40 |
|---|-------------------|--------------|
| Main service pump operating system pressure | bar (psi) | 230 (3336) |
| Flow at system pressure (@ 2800rpm) | ltr/min (gal/min) | 47.6 (10.5) |
| Maximum auxiliary flow (@ 230bar) | ltr/min (gal/min) | 47.6 (10.21) |
| Cycle times | | seconds |
| Boom raise | | 7.3 |
| Boom lower | | 5.4 |
| Extend | | 5.8 |
| Retract | | 3.7 |
| Bucket dump | | 2.8 |
| Bucket crowd | | 3.9 |

SAFETY CHECK VALVES

Fitted to crowd, extension and lift rams.

CAB

Quiet, safe and comfortable cab conforms to ROPS ISO3471 and FOPS ISO 3449. Internal noise 85 Lpa. Radio console. Arm rest. Tinted glass all round with laminated front and roof screen. Front, rear screen wash/wipe and heater/screen demister. Opening door window. Optional air conditioning or face-level fan. Visual warning system for coolant temperature, engine oil pressure, air cleaner, battery charge, transmission oil pressure, engine temperature, fuel gauge and hourmeter.

Boom control lever incorporating forward/reverse switch. Throttle and brake pedals floor mounted. Optional fabric or vinyl adjustable. Adjustable deluxe suspension seat with side mounted park brake lever. Automatic eye level audio-visual load moment indicator warning system receiving a signal from a load sensor on the rear axle. This system continuously monitors the machine's forward stability and leaves the operator in control at all times.

STEERING

Full hydrostatic power steering. Permanent 4WS with 32° lock front and rear axles provides exceptional manoeuvrability.

OPTIONS AND ACCESSORIES

Options: Road lights, work lights, rotating flashing beacon, fire extinguisher, front screen guard, sun blind, traction, industrial or semi-turf tyres, chaff guard, canopy, mechanical compact loadall quickhitch or and Skid Steer quickhitch, battery isolator, industrial or semi-turf tyres, chaff guards, canopy. **Cab options:** Air conditioning, face level fan, opening door window, screen guard.

Attachments: Compact loadall quickhitch: GP shovel with teeth or toeplate, industrial or floating forks, bale spike, power grab. Skid Steer Quickhitch: GP shovel with teeth or toeplate, 6-in-1 shovel, industrial or floating forks, industrial grapple, sweeper/collector, muck fork and grab, low back shovel.



JCB Sales Limited, Rocester, Staffordshire, United Kingdom ST14 5JP. Tel: +44 (0)1889 590312. Email: salesinfo@jcb.com

Download the very latest information on this product range at: www.jcb.com

©2009 JCB Sales. All rights reserved. No part of this publication may be reproduced, stored in a retrieval system, or transmitted in any form or by any other means, electronic, mechanical, photocopying or otherwise, without prior permission from JCB Sales. JCB reserves the right to change specifications without notice. Illustrations and specifications shown may include optional equipment and accessories. The JCB logo is a registered trademark of J C Bamford Excavators Ltd.