

KOMATSU®

PW130-7

NET HORSEPOWER
78 kW 105 HP @ 2.200 rpm

OPERATING WEIGHT
12.770 - 15.110 kg

BUCKET CAPACITY
max. 0,94 m³

PW
130

HYDRAULIC WHEELED EXCAVATOR



PW130-7

WALK-AROUND

The PW130-7 is a rugged, productive, all-European machine. Designed and expressly built for European markets, it delivers productivity, reliability and operator comforts in a robust, environmentally-friendly package. Komatsu's exclusive, on-board, HydraMind system assists in all operations, providing enhanced machine performance that's always perfectly matched to the task.

What's new on Dash 7:

- High lifting capacity
- Easier maintenance and serviceability
- Improved operator comfort
- Lower noise
- Higher drawbar pull
- Advanced Attachment Control
- Multi-function colour monitor

Advanced Attachment Control

The PW130-7 can be optionally equipped to handle a wide variety of attachments. The advanced attachment control system features:

- Operator selectable hydraulic flow control
- Adjustable presets for rapid attachment changeover
- Attachment piping options for breaker, clamshell or crusher

Undercarriage

- Designed for high ground clearance
- Virtually zero axle rocking with outboard wet disc system
- Powerful drawbar pull
- Automatic 3-speed travel
- 30 km/h maximum travel speed

High productivity

- The powerful turbocharged and air-to-air aftercooled Komatsu SAA4D102E-2 provides 78 kW/105 HP
- High lifting capacity and good stability

Excellent reliability and durability

- Reliable major components designed and built by Komatsu
- Exceptionally reliable electronic devices



NET HORSEPOWER
78 kW 105 HP

OPERATING WEIGHT
12.770 - 15.110 kg

BUCKET CAPACITY
max. 0,94 m³

SpaceCab™

The new PW130-7's cabin space has been increased by 14%, offering an exceptionally roomy operating environment.

- Sealed and pressurised cab with standard climate control
- Low-noise design
- Low-vibration design with cabin damper mounting
- Cab moved forward for better visibility
- Ergonomic control levers
- Seat specially designed for wheeled machines, with exceptional extra comfort

In harmony with the environment

- The low emission engine meets EC Stage II emissions standards with increased power and machine productivity
- The economy mode reduces fuel consumption
- Low operating noise
- Designed for easy end-of-life recycling



EMMS

EMMS (Equipment Management and Monitoring System)

The EMMS is a highly sophisticated system, controlling and monitoring all the excavator functions. The user interface is highly intuitive and provides the operator with easy access to a huge range of functions and operating information.

Four working modes

The PW130-7 is equipped with three working modes: (A, E, B), plus a lifting mode (L). Each mode is designed to match the engine speed, pump speed, and system pressure with the current operating requirement. This provides the flexibility to match equipment performance to the job at hand.



On-screen symbols

- 1 Working mode
- 2 Service meter and clock
- 3 Engine water gauge
- 4 Engine water temperature warning
- 5 Hydraulic oil gauge
- 6 Hydraulic oil temperature warning
- 7 Fuel gauge
- 8 Fuel low level warning
- 9 Travel direction
- 10 Travel mode
- 11 Auto deceleration
- 12 Suspension lock
- 13 Swing lock
- 14 Swing position

Push-button control switches

- 1 Working mode select
- 2 Creep speed
- 3 High/low speed select
- 4 Control lever lock
- 5 Menu select key
- 6 Service menu
- 7 Engine auto deceleration
- 8 Buzzer cancel
- 9 Brightness adjust
- 10 Suspension auto lock
- 11 Suspension lock
- 12 Accept key
- 13 Scroll down
- 14 Scroll up
- 15 Undo switch
- 16 Rear left outrigger/blade
- 17 Front left outrigger/blade
- 18 Front right outrigger
- 19 Rear right outrigger

Active mode

For maximum power and fast cycle times. Normally used for heavy operations such as hard digging and loading. This mode allows access to the 'PowerMax' function to temporarily increase the digging force by 7% for added power in tough situations.

Economy mode

The environmentally-friendly mode. For running more quietly during operations at night and/or in urban areas. Fuel consumption and exhaust emissions are reduced.

Breaker mode

Delivers optimal hydraulic pressure, flow and engine RPMs for powerful breaker operations.

Lifting mode

Increases the lifting capacity 7% by raising the hydraulic pressure. This mode supports safe lifting operations.

Working mode	Application	Advantage
A	Active mode	<ul style="list-style-type: none"> • Maximum production/power • Fast cycle times
E	Economy mode	<ul style="list-style-type: none"> • Excellent fuel economy
B	Breaker mode	<ul style="list-style-type: none"> • Optimum engine RPMs and hydraulic flow
L	Lifting mode	<ul style="list-style-type: none"> • Hydraulic pressure has been increased by 7%

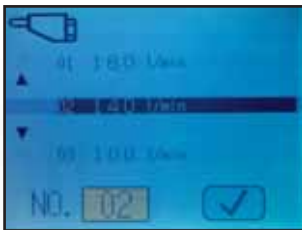

Hydraulic flow general adjustment screen in B (breaker) mode



Fine tune hydraulic flow adjustment screen in B (breaker) mode



Fine tune hydraulic flow adjustment screen in A (active) or E (economy) mode



Password screen

Easy to see and easy to use

Superb recognition colour LCD screens for each mode. Letters and numbers are combined with colour images for exceptionally clear and easy-to-read information. The high-resolution screen is easy to read in bright sunlight and in all lighting conditions.

Automatic three-speed travel

The travel speed is automatically shifted from high to low speed, according to the ground conditions.

	High	Low	Auto	Creep
Travel speed	30 km/h	9,0 km/h	0 - 30 km/h	2,0 km/h

Fingertip hydraulic pump oil flow adjustment

From the LCD monitor, you can automatically select the optimal hydraulic pump oil flow for breaking, crushing, and other operations in the B, A or E modes. Also, when simultaneously operating with attachments and work equipment, the flow to the attachment is reduced automatically, thus delivering a smooth movement of the work equipment.

Password protection

Prevents unauthorised machine use or transport. The engine cannot be started without your four-digit use or password.

For total security, the battery is connected directly to the starter motor. Both the starter and the engine need the password.

The password can be activated and deactivated upon request.

WORKING ENVIRONMENT

PW130-7's cab interior is spacious and provides a comfortable working environment...

SpaceCab™

Comfortable cab

The new PW130-7 inner cab volume is 14% greater than the Dash 6 models, offering an exceptionally comfortable operating environment. The large cab enables the seat, with headrest, to be reclined to horizontal.

Pressurised cab

The standard-equipped climate control, air filter and a higher internal air pressure resist dust entry into the cab.

Low-noise design

Noise levels are substantially reduced; engine noise as well as swing and hydraulics operations noise.

Cab damper mounting for low vibration levels

PW130-7 uses a new and improved viscous damping cab mount system that incorporates a longer stroke plus an added spring. The new cab damper mounting, combined with strengthened left and right-side decks, aids the reduction of vibrations to the operator's seat.

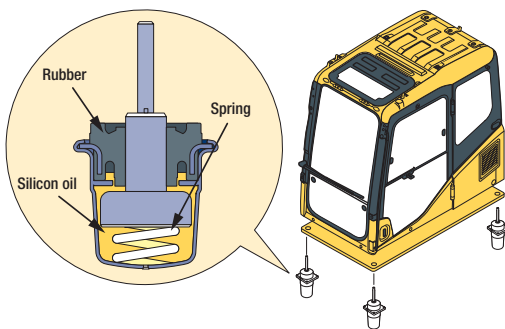

Outer air filter

Easy removal/installation of the air conditioner filter element, without tools facilitates easier cleaning.



Large sun roof with integrated sun shade



12-Volt power supply and (optional) radio cassette



Climate control



Tiltable steering wheel with several functions; wiper control, indicator, horn, and head lights

Safety features

Multi-position controls

The multi-position, proportional pressure control levers allow the operator to work in comfort whilst maintaining precise control. A double-slide mechanism allows the seat and controllers to move together, or independently, allowing the operator to position the controllers for maximum productivity and comfort.



Hot and cool box



Ergonomic 3 button lever



Seat sliding range: 340 mm



Defroster/demister

Improved, wide visibility

The right side window pillar has been removed and the rear pillar reshaped to provide greater visibility. Blind spots have been decreased by 34%.

Pump/engine room partition

This prevents hydraulic oil from spraying onto the engine to reduce the risk of fire.

Thermal and fan guards

Are placed around high-temperature parts of the engine. The fan belt and pulleys are well protected.

Steps with non-skid surface and large handrail

Steps with non-slip surfacing ensure safer maintenance.

Thermal guard



Non-slip sheet



Large handrail for safe access



FLEXIBILITY

ARMS

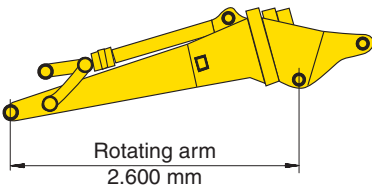
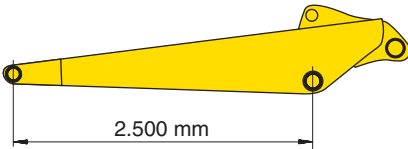
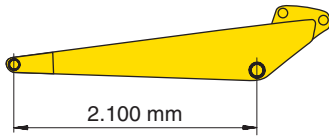

BOOMS

Mono boom

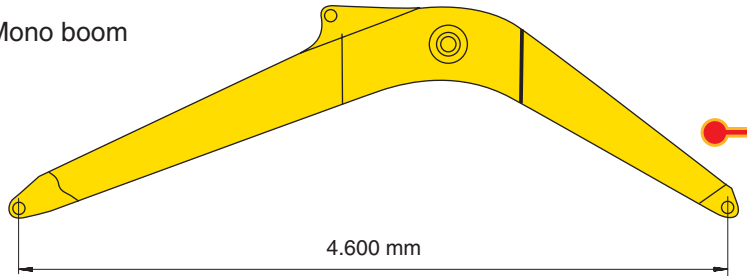

Two-piece boom

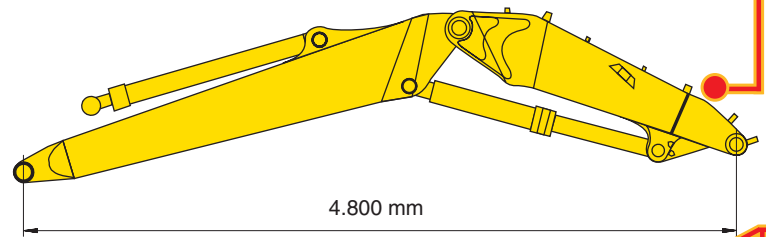

Parallel blade



Outriggers

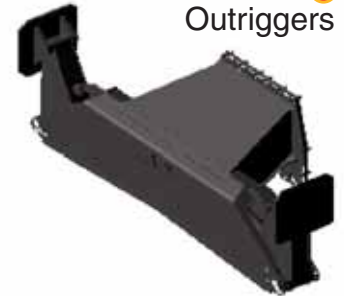

Additional hydraulic circuits

A 2-way additional hydraulic circuit, electrically controlled from the wrist control levers, is fitted as standard.



Outriggers

Independently controlled outriggers are optionally available on both, the front and rear of the machine. The cylinder protections are standard on the outriggers.

The PW130-7 can be specified with an enormous range of work equipment and undercarriage attachments to meet the needs of almost any application.

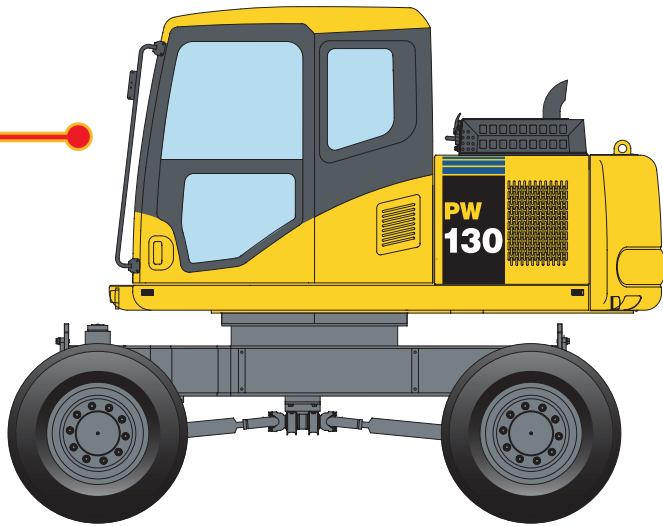

Parallel blade



Outriggers

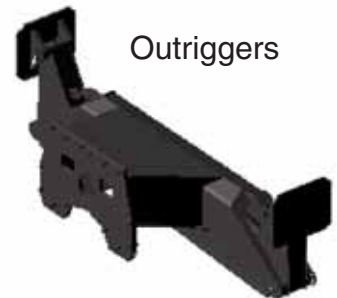

Attachments commonality & functionality

The stabilizer and dozer blade are interchangeable, and therefore can be attached on the front or rear of the chassis. The stabilizer and dozer blade are controllable from the monitor panel. The monitor panel has four buttons that allow individual attachment operation as well as collective operation.



Toolbox
Tough, secure toolbox, integrated in the mudguards. Optionally fitted on both sides of the undercarriage.



Dozer blade
A parallel blade is available with standard cylinders protector for both the front and rear of the machine.
Dimensions: 2.550 mm x 520 mm

EASY OPERATION

As well as operating the standard work equipment movements, the RH wrist control lever is also used to operate the undercarriage. When used in conjunction with the selection switch on the control panel, full independent control of outriggers and dozer blade is immediately available. This feature, together with the automatic axle lock, enables the machine to be moved, stabilized and operated extremely quickly.

Clamshell/breaker control

Clockwise clamshell rotation. Also used for breaker operation when B.O. mode is selected.

Clamshell control

Anti-clock wise clamshell rotation.



Undercarriage attachment control

After a single touch, the lever can be used to precisely operate the selected undercarriage attachment. After operating the undercarriage attachments, a single touch reverts the lever into standard boom operation.

Travel control

A rock button is installed on the right hand lever, it controls the travel operation into forward, neutral and rear. From the consistent weighting of the steering to the predictable and precise operation of the travel and brake pedals, the operator will always feel in complete control during travelling.



Travel pedal

PRODUCTIVITY FEATURES

Proven reliability and fuel economy

The PW130-7 mounts the Komatsu SAA4D102E-2 engine, an engine with proven performance thanks to the experience gained on the Dash 6 model of the PW130.



Safe and precise lifting

PW130-7's stability is one of the best in its class. The machine is equipped with boom safety valves and overload caution as standard. This combined with the control of HydraulMind and the power of the lifting mode, gives incredible safe and precise lifting performance. Example: The over-front lifting capacity (reach 4,5 m over front, height 1,5 m) has a capacity of 5,6 tonnes (dozer blade down).

PowerMax function

PowerMax can be selected by depressing a joystick button for an instant burst of power to help break through tough digging situations. The PowerMax function is available in the A and E working mode.

Bucket digging force*: 8.500 kg

Arm crowd force*: 7.300 kg

* Measured with PowerMax function, 2.100 mm arm and ISO rating

Superb visibility

Excellent all-round visibility is provided by large panoramic windows. Front visibility is further improved by the use of the Komatsu patented wiper system. When not in use the wiper parks on the cab frame itself with no contact with the front window. As well as giving excellent visibility, this systems avoids the need to disconnect the wiper before lifting the front window. The standard new plexiglas roof with sun visor gives the operator a better view of overhead obstacles and machine operations. It also allows more natural light to illuminate the cab's interior.



VHMS

VHMS (Vehicle Health Monitoring System)

The VHMS's precise health-check system indicates all of the machine's running conditions. At the beginning of, and during, each work shift, abnormality information and machine functions can be checked from the operator's seat.

New features: VHMS machine health monitoring

- Up to four different mechanical system measurements can be monitored at the same time.
- A "Maintenance Indicator" function has been added (Filter and oil replacement time display function).
- Mechanical system failures are now monitored, in addition to electrical system failures.
- Failures are indicated with a 6-digit failure code.

Displays running conditions and abnormality indications

At the operator's fingertips: the VHMS controller monitors engine oil level, cooling water level, fuel level, engine water temperature, engine oil pressure, battery charging level, air filter clogging, and more.

The monitor also indicates whenever abnormalities are detected.

Maintenance alert assistance

The VHMS monitor alerts when oil and filters need to be replaced.

Operation data memory

The system memorises machine operating data such as engine output, hydraulic pressure, and more.

Trouble data memory

The monitor stores and recalls electrical system and mechanical system failures and abnormalities for effective troubleshooting. The twenty most-recent electrical system failures are stored. Mechanical system failures cannot be erased, ensuring accurate documentation of vital service management information.

VHMS 'real time monitoring system'

The 'real time monitoring system' displays up to four different operating parameters simultaneously, giving the mechanic a total overview for faster troubleshooting. Parameters include operating conditions such as hydraulic oil pressure, engine RPMs, various voltages and currents, and even temperature measurement.

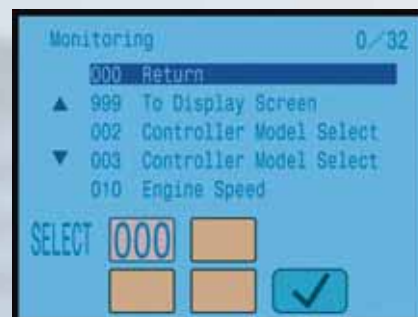

Real time monitoring

Reducing maintenance costs

Replacement intervals for engine oil and filters

High-performance filters are used in the hydraulic circuit and engine. Replacement intervals for the hydraulic oil filter are significantly extended, reducing maintenance costs.

Replacement intervals	PW130-7
Engine oil	500 h
Engine oil filter	500 h
Hydraulic oil	5.000 h
Hydraulic oil filter	500 h



Designed and built for strength

Using the latest computer aided design techniques and exhaustive testing, the boom and arm designs have been optimised for strength and durability.

The highly automated manufacturing process uses the very latest equipment and quality control techniques. Critical welding is carried out by robots to ensure an extremely high quality and consistent product.

Precision engineered pin and bush system. The key work equipment joints use a chrome plated pin and bronze bushing system to provide minimal play and extended durability.



Trouble data memory

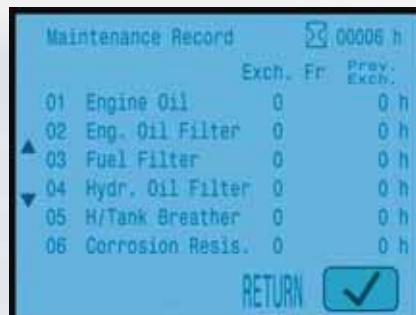

Maintenance record



Maintenance mode change

SPECIFICATIONS



ENGINE

Model	Komatsu SAA4D102E-2
Type	Direct injection, water-cooled, emissionised, turbocharged, after-cooled diesel
Rated capacity	78 kW/105 HP (ISO 9249 Net)
at engine speed	2.200 rpm
No. of cylinders	4
Bore x stroke	102 x 120 mm
Displacement	3,9 ltr
Batteries	2 x 12 V/95 Ah
Alternator	24 V/40 A
Starter motor	24 V/5,5 kW
Air filter type	Double element type with monitor panel dust indicator and auto dust evacuator
Cooling	Suction type cooling fan



HYDRAULIC SYSTEM

Type	HydrauMind. Closed-centre system with load sensing and pressure compensation valves
Additional circuits	1 additional circuit installed as standard
Main pump	Variable displacement piston pump supplying boom, arm, bucket, swing and travel circuits
Maximum pump flow	236 ltr/min
Relief valve settings	
Implement	365 bar
Travel	420 bar
Swing	325 bar
Pilot circuit	36 bar



COOLANT AND LUBRICANT CAPACITY (REFILLING)

Fuel tank	250 ltr
Radiator	15,7 ltr
Engine oil	16 ltr
Swing drive	2,5 ltr
Hydraulic tank	100 ltr
Transmission	4,85 ltr
Front differential	10,5 ltr
Rear differential	9,5 ltr
Front axle hub	2,5 ltr
Rear axle hub	2,0 ltr
Swing pinion grease bath amount	9,0 ltr



ENVIRONMENT

Engine emissions	Fully complies with EC Stage II exhaust emission regulations
Noise levels	
LwA external	101 dB(A) (2000/14/EC)
LpA operator ear	71 dB(A) (ISO 6369 dynamic test)



SWING SYSTEM

Type	Axial piston motor driving through planetary double reduction gearbox
Swing lock	Electrically actuated wet multi-disc brake integrated into swing motor. An additional mechanical pin can be engaged from inside the operator cab
Swing speed	0 - 11,5 rpm
Swing torque	31 kNm



TRANSMISSION

Type	Fully automatic power shift transmission with permanent 4 wheel drive
Travel motors	One variable displacement axial piston motor
Maximum pressure	355 bar
Travel modes	Automatic + 3 travel modes
Max. travel speeds	
Hi / Lo / Creep	30,0 / 9,0 / 2,0 km/h
	A max. speed restriction of 20 km/h is available as an option.
Maximum drawbar pull	8.700 kg
Front axle load	Lower than 8.200 kg
Rear axle load	Lower than 7.400 kg
Axle oscillation	7° Lockable in any position from the operator cab.



BRAKE SYSTEM

Type	Dual circuit hydraulic braking system supplied from a separate gear pump.
Service brakes	Pedal actuated wet multi-disc brakes integrated into the axle hubs.
Parking brake	Electrically actuated wet multi-disc "spring actuation hydraulic release" brake integrated into the transmission.



STEERING SYSTEM

Steering control	Hydraulic steering system supplied from a separate gear pump and controlled through LS orbital & priority valves.
Minimum turning radius	6.790 mm (to center of outer wheel)



OPERATING WEIGHT (APPR.)

Operating weight, including specified work equipment, operator, lubricant, coolant, full fuel tank and the standard equipment. Weights are without bucket.

Undercarriage type	Mono boom	Two-piece boom	Two-piece boom + rotating arm
Rear blade	12.770 kg	13.100 kg	–
Rear outrigger	13.140 kg	13.470 kg	–
2 outriggers + blade	13.590 kg	13.920 kg	14.110 kg
4 outriggers	13.960 kg	14.290 kg	15.110 kg



BUCKET OPTIONS & DIGGING FORCES

Specifications and equipment may vary according to regional availability.

BUCKET AND ARM COMBINATIONS					
Bucket			Arm length		
Width	Capacity (SAE)	Weight	2.100 mm	2.500 mm	Rotating arm
400 mm	0,18 m ³	305 kg	○	○	○
500 mm	0,25 m ³	320 kg	○	○	○
600 mm	0,32 m ³	350 kg	○	○	○
700 mm	0,40 m ³	390 kg	○	○	○
800 mm	0,48 m ³	440 kg	○	○	○
900 mm	0,56 m ³	475 kg	○	○	□
1.000 mm	0,64 m ³	505 kg	○	○	□
1.100 mm	0,72 m ³	560 kg	○	□	△
1.200 mm	0,80 m ³	620 kg	□	□	△
1.200 mm	0,94 m ³	625 kg	□	□	–

Please consult with your distributor for the correct selection of buckets and attachments to suit the application. The recommendations are given as a guide only, based on typical operating conditions.

○ Material weight up to 1,8 t/m³
 □ Material weight up to 1,5 t/m³
 △ Material weight up to 1,2 t/m³

BUCKET AND ARM FORCE			
Arm length	2.100 mm	2.500 mm	Rotating arm
Bucket digging force	7.800 kg	7.800 kg	7.800 kg
Bucket digging force at PowerMax	8.500 kg	8.500 kg	8.500 kg
Arm crowd force	6.700 kg	5.400 kg	5.400 kg
Arm crowd force at PowerMax	7.300 kg	6.100 kg	5.900 kg

DIMENSIONS

MONO BOOM

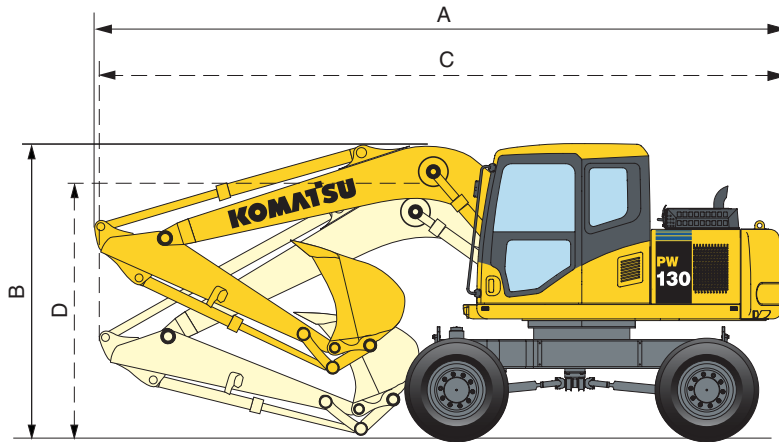

Driving position		
Arm length	A	B
2.100 mm	7.576 mm	3.105 mm
2.500 mm	7.476 mm	3.391 mm

Transport position		
Arm length	C	D
2.100 mm	7.540 mm	2.835 mm
2.500 mm	7.520 mm	3.255 mm

TWO-PIECE BOOM

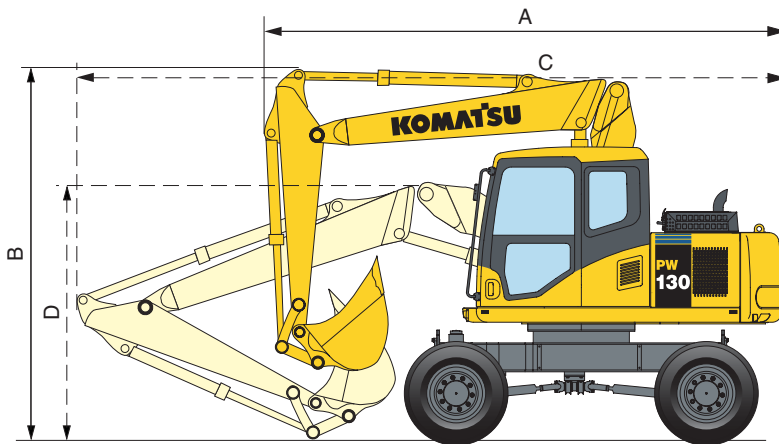

Driving position		
Arm length	A	B
2.100 mm	6.007 mm	3.937 mm
2.500 mm	5.869 mm	3.937 mm

Transport position		
Arm length	C	D
2.100 mm	7.777 mm	2.785 mm
2.500 mm	7.790 mm	2.860 mm

TWO-PIECE BOOM + ROTATING ARM

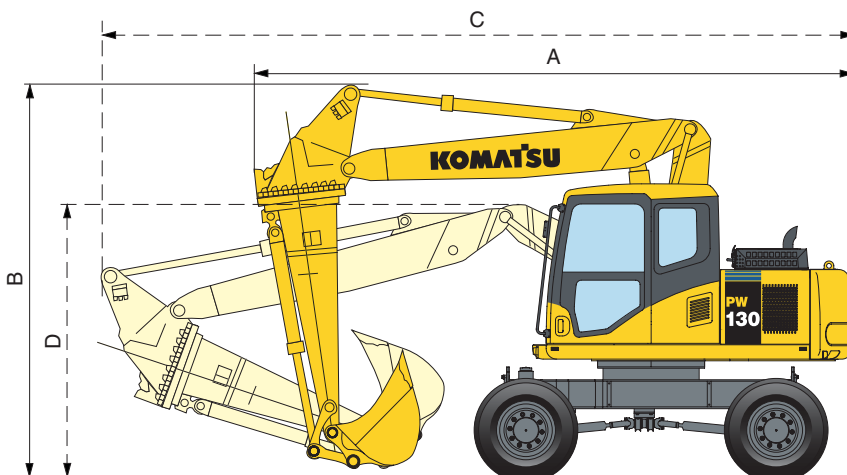

Driving position		
Arm length	A	B
2.600 m	5.938 mm	3.956 mm

Transport position		
Arm length	C	D
2.600 m	7.655 mm	2.610 mm

DIMENSIONS & UNDERCARRIAGE

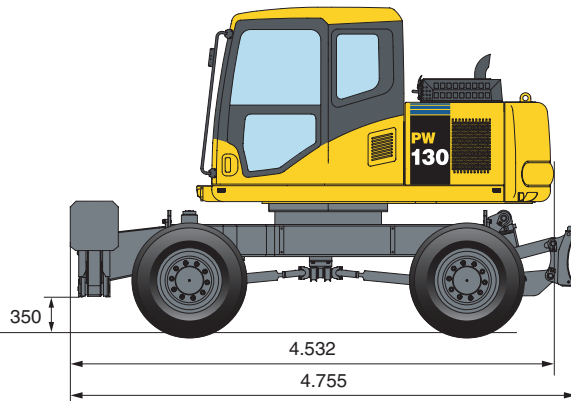
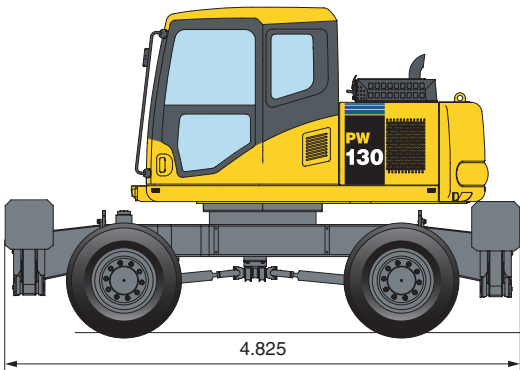
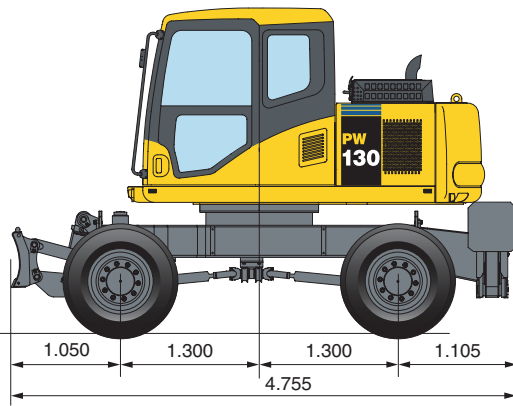
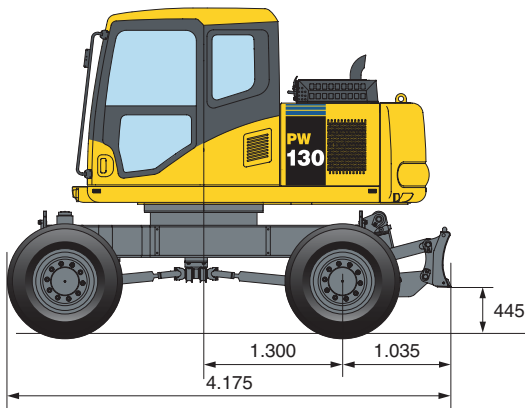
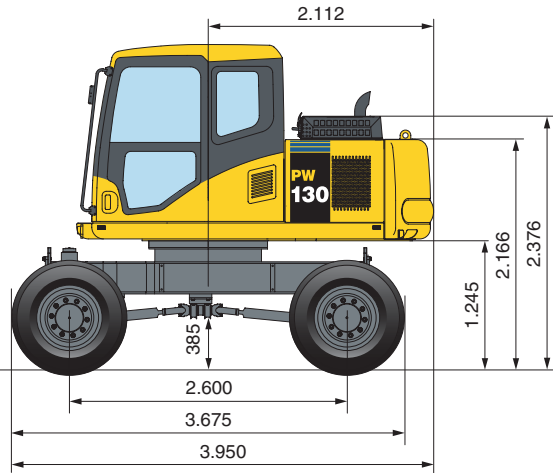
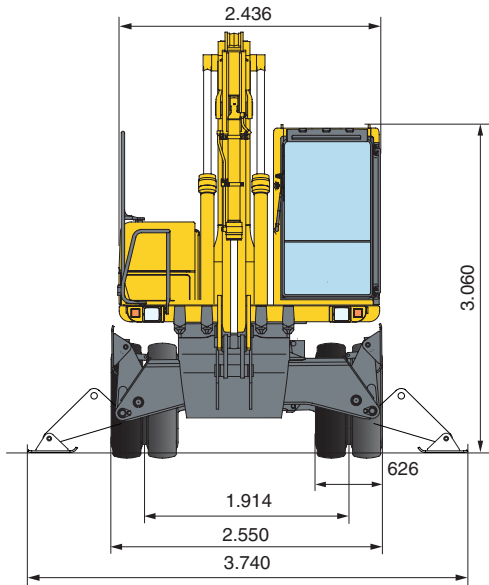

WORKING RANGE

MONO BOOM

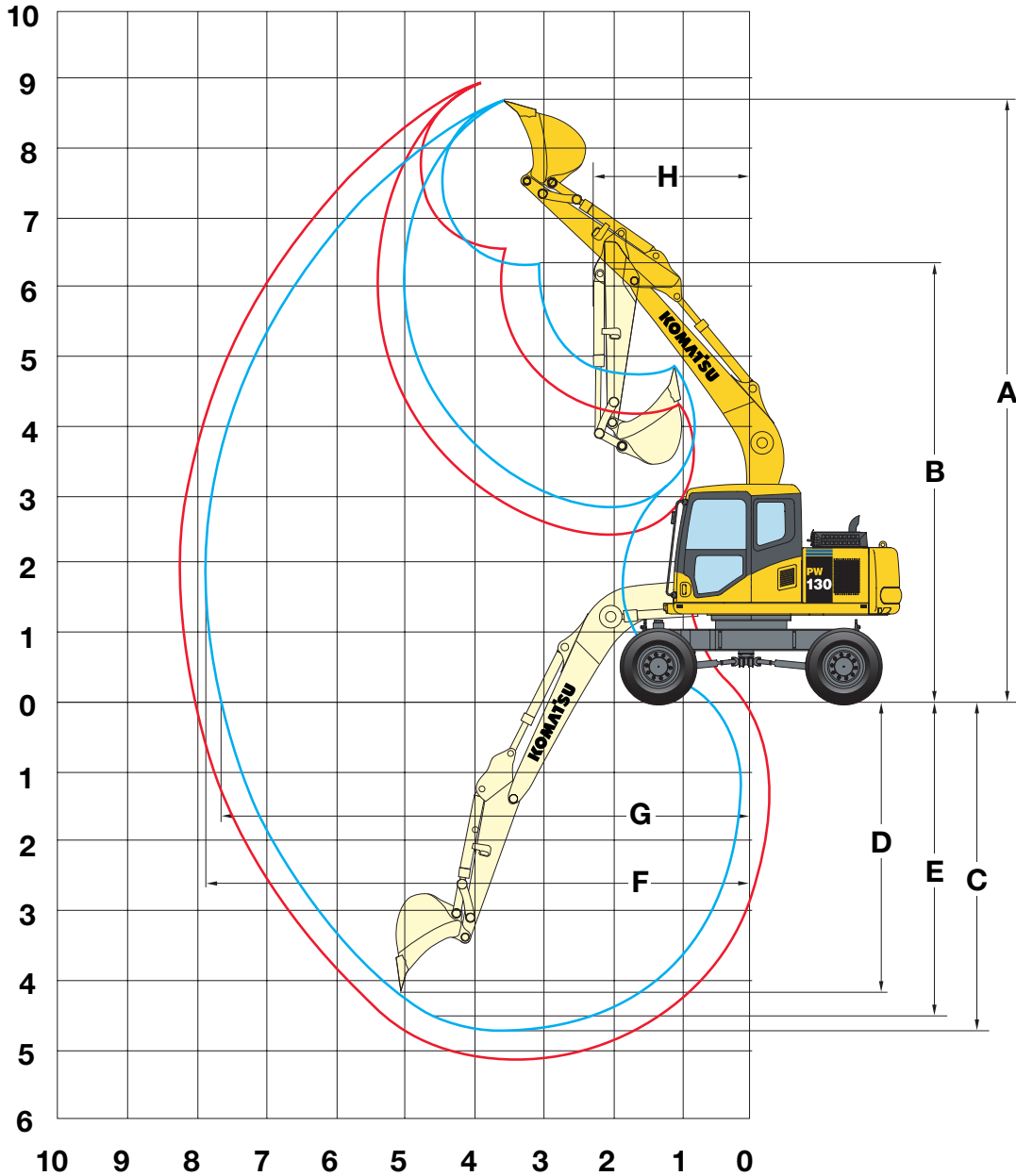

ARM LENGTH		2.100 mm	2.500 mm
A	Max. digging height	8.660 mm	8.900 mm
B	Max. dumping height	6.290 mm	6.530 mm
C	Max. digging depth	4.730 mm	5.130 mm
D	Max. vertical wall digging depth	4.175 mm	4.560 mm
E	Max. digging depth of cut for 2,44 m level	4.495 mm	4.925 mm
F	Max. digging reach	7.895 mm	8.265 mm
G	Max. digging reach at ground level	7.690 mm	8.070 mm
H	Min. swing radius	2.320 mm	2.400 mm

TWO-PIECE BOOM

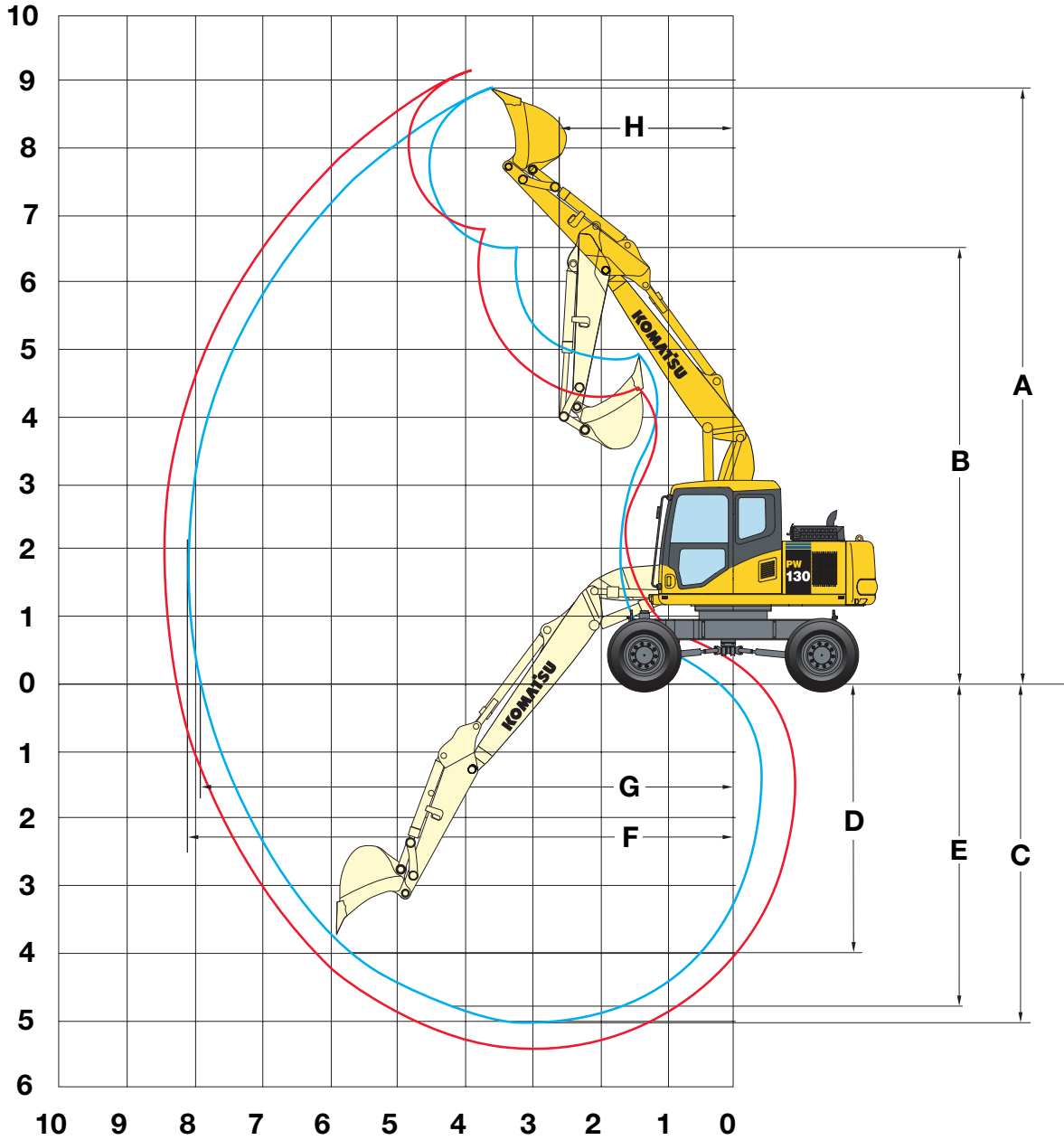

ARM LENGTH		2.100 mm	2.500 mm
A	Max. digging height	8.930 mm	9.190 mm
B	Max. dumping height	6.540 mm	6.905 mm
C	Max. digging depth	5.010 mm	5.410 mm
D	Max. vertical wall digging depth	3.978 mm	4.365 mm
E	Max. digging depth of cut for 2,44 m level	4.779 mm	5.202 mm
F	Max. digging reach	8.142 mm	8.518 mm
G	Max. digging reach at ground level	7.945 mm	8.331 mm
H	Min. swing radius	2.605 mm	2.650 mm

WORKING RANGE



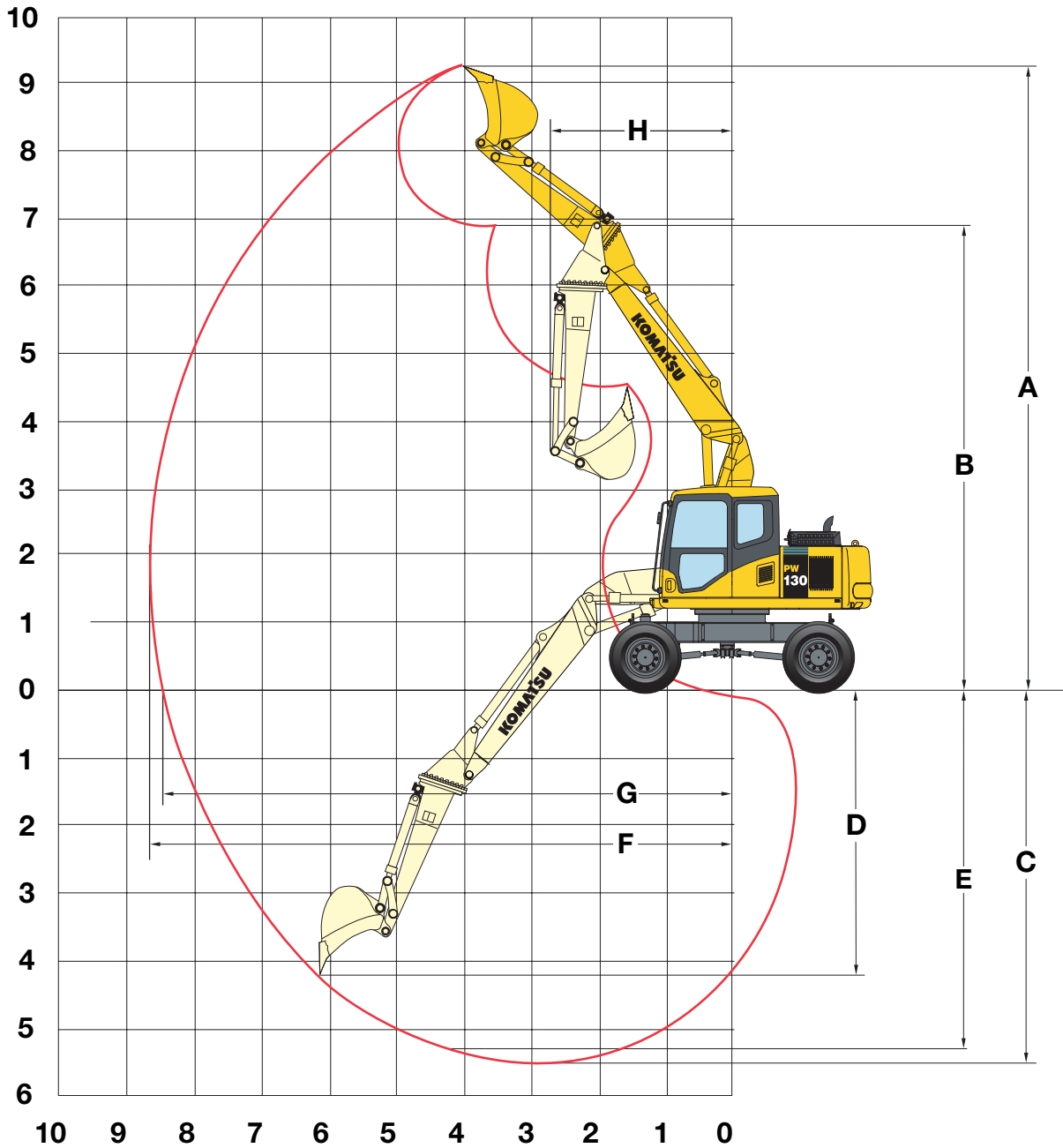

TWO-PIECE BOOM + ROTATING ARM



ARM LENGTH		2.600 mm
A	Max. digging height	9.255 mm
B	Max. dumping height	6.880 mm
C	Max. digging depth	5.500 mm
D	Max. vertical wall digging depth	4.215 mm
E	Max. digging depth of cut for 2,44 m level	5.295 mm
F	Max. digging reach	8.615 mm
G	Max. digging reach at ground level	8.430 mm
H	Min. swing radius	2.675 mm

LIFTING CAPACITY

MONO BOOM

Arm length	A	⊗		6,0 m		4,5 m		3,0 m		1,5 m	
		⌋	⌋	⌋	⌋	⌋	⌋	⌋	⌋	⌋	⌋
B		⌋	⌋	⌋	⌋	⌋	⌋	⌋	⌋	⌋	⌋
 Without stabilizer	7,5 m	kg	*2.800	*2.800							
	6,0 m	kg	*2.300	1.800		*3.450	2.750				
	4,5 m	kg	*2.150	1.350	3.050	1.600	*3.800	2.700			
	3,0 m	kg	*2.200	1.150	3.000	1.550	*4.700	2.500	*6.750	4.750	
	1,5 m	kg	2.200	1.100	2.900	1.450	4.650	2.300	*7.400	4.200	
	0,0 m	kg	2.300	1.100	2.800	1.400	4.500	2.150	*7.550	3.950	
	-1,5 m	kg	2.650	1.300	2.800	1.350	4.550	2.100	*8.950	3.950	*5.800
-3,0 m	kg	3.700	1.850			4.550	2.200	*7.200	4.100		
 Rear outrigger	7,5 m	kg	*2.800	*2.800							
	6,0 m	kg	*2.300	*2.300		*3.450	*3.450				
	4,5 m	kg	*2.150	*2.150	*3.550	2.450	*3.800	*3.800			
	3,0 m	kg	*2.200	*2.200	*3.700	2.400	*4.700	3.900	*6.750	*6.750	
	1,5 m	kg	*2.350	2.150	3.600	2.300	*5.650	3.650	*7.400	7.050	
	0,0 m	kg	*2.700	2.250	3.550	2.250	5.700	3.500	*7.550	6.800	*5.800
	-1,5 m	kg	3.350	2.600	3.500	2.250	5.650	3.450	*8.950	6.800	
-3,0 m	kg	*3.850	3.550			*4.800	3.550	*7.200	6.950		
 Rear blade	7,5 m	kg	*2.800	*2.800							
	6,0 m	kg	*2.300	2.200		*3.450	*3.300				
	4,5 m	kg	*2.150	1.650	*3.550	1.950	*3.800	3.250			
	3,0 m	kg	*2.200	1.450	3.850	1.850	*4.700	3.050	*6.750	5.850	
	1,5 m	kg	*2.350	1.350	3.750	1.800	*5.650	2.800	*7.400	5.250	
	0,0 m	kg	*2.700	1.400	3.650	1.700	6.000	2.650	*7.550	5.000	
	-1,5 m	kg	*3.400	1.650	3.650	1.700	5.900	2.650	*8.950	5.000	*5.800
-3,0 m	kg	*3.850	2.250			*4.800	2.700	*7.200	5.150		
 Front outrigger + rear blade	7,5 m	kg	*2.800	*2.800							
	6,0 m	kg	*2.300	*2.300		*3.450	*3.450				
	4,5 m	kg	*2.150	*2.150	*3.550	2.950	*3.800	*3.800			
	3,0 m	kg	*2.200	1.850	*3.850	2.900	*4.700	*4.700	*6.750	*6.750	
	1,5 m	kg	*2.350	1.750	*4.000	2.800	*5.650	4.450	*7.400	*7.400	
	0,0 m	kg	*2.700	1.850	3.950	2.700	*6.150	4.250	*7.550	*7.550	
	-1,5 m	kg	*3.400	2.150	3.900	2.700	*6.000	4.200	*8.950	8.650	*5.800
-3,0 m	kg	*3.850	2.900			*4.800	4.300	*7.200	*7.200		

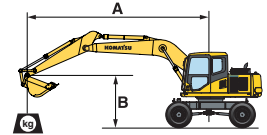

Arm length 2.100 mm

A – Reach from swing center

B – Bucket hook height

C – Lifting capacities, including bucket (462 kg), bucket linkage (84 kg) and bucket cylinder (92 kg)

⌋ – Rating over front

⌋ – Rating over side

⊗ – Rating at maximum reach

When removing bucket, linkage or cylinder, lifting capacities can be increased by their respective weights.

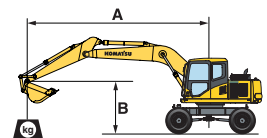

Arm length 2.500 mm

A – Reach from swing center

B – Bucket hook height





C – Lifting capacities, including bucket (462 kg), bucket linkage (84 kg) and bucket cylinder (92 kg)

⌋ – Rating over front

⌋ – Rating over side

⊗ – Rating at maximum reach

When removing bucket, linkage or cylinder, lifting capacities can be increased by their respective weights.

 Without stabilizer	7,5 m	kg	*2.200	*2.200		*2.500	*2.500				
	6,0 m	kg	*1.850	1.600	*2.000	1.600					
	4,5 m	kg	*1.750	1.200	3.100	1.650	*3.450	2.750			
	3,0 m	kg	*1.800	1.050	3.000	1.550	*4.400	2.600	*6.050	5.000	
	1,5 m	kg	*1.950	1.000	2.900	1.500	4.750	2.350	*8.650	4.350	
	0,0 m	kg	2.100	1.000	2.800	1.400	4.550	2.200	*7.950	4.000	
	-1,5 m	kg	2.400	1.150	2.800	1.350	4.450	2.100	*9.300	3.950	*5.250
-3,0 m	kg	3.150	1.550			4.450	2.150	*7.900	4.050	*8.800	
 Rear outrigger	7,5 m	kg	*2.200	*2.200		*2.500	*2.500				
	6,0 m	kg	*1.850	*1.850	*2.000	*2.000					
	4,5 m	kg	*1.750	*1.750	*3.300	2.500	*3.450	*3.450			
	3,0 m	kg	*1.800	1.700	*3.700	2.450	*4.400	3.950	*6.050	*6.050	
	1,5 m	kg	*1.950	1.650	3.650	2.350	*5.400	3.700	*8.650	7.250	
	0,0 m	kg	*2.200	1.700	3.550	2.250	5.750	3.550	*7.950	6.850	
	-1,5 m	kg	*2.750	1.900	3.500	2.250	5.650	3.450	*9.300	6.800	*5.250
-3,0 m	kg	*3.750	2.500			*5.250	3.450	*7.900	6.900	*8.800	
 Rear blade	7,5 m	kg	*2.200	*2.200		*2.500	*2.500				
	6,0 m	kg	*1.850	*1.850	*2.000	1.950					
	4,5 m	kg	*1.750	1.500	*3.300	2.000	*3.450	*3.300			
	3,0 m	kg	*1.800	1.300	*3.700	1.900	*4.400	3.100	*6.050	*6.050	
	1,5 m	kg	*1.950	1.250	3.800	1.800	*5.400	2.900	*8.650	5.400	
	0,0 m	kg	*2.200	1.300	3.700	1.750	6.000	2.700	*7.950	5.050	
	-1,5 m	kg	*2.750	1.450	3.650	1.700	5.950	2.650	*9.300	5.000	*5.250
-3,0 m	kg	*3.750	1.950			*5.250	2.650	*7.900	5.100	*8.800	
 Front outrigger + rear blade	7,5 m	kg	*2.200	*2.200		*2.500	*2.500				
	6,0 m	kg	*1.850	*1.850	*2.000	*2.000					
	4,5 m	kg	*1.750	*1.750	*3.300	3.000	*3.450	*3.450			
	3,0 m	kg	*1.800	*1.800	*3.700	2.950	*4.400	*4.400	*6.050	*6.050	
	1,5 m	kg	*1.950	*1.950	4.050	2.800	*5.400	4.500	*8.650	*8.650	
	0,0 m	kg	*2.200	2.050	3.950	2.750	*6.050	4.300	*7.950	*7.950	
	-1,5 m	kg	*2.750	2.350	3.900	2.700	*6.100	4.250	*9.300	8.650	*5.250
-3,0 m	kg	*3.750	3.050			*5.250	4.250	*7.900	*7.900	*8.800	





* Load is limited by hydraulic capacity rather than tipping.

Ratings are based on SAE Standard No. J1097.

Rated loads do not exceed 87% of hydraulic lift capacity or 75% of tipping load.

LIFTING CAPACITY

TWO-PIECE BOOM

Arm length	A	⊗		6,0 m		4,5 m		3,0 m		1,5 m		
		⊗	⊗	⊗	⊗	⊗	⊗	⊗	⊗	⊗	⊗	
 Without stabilizer	7,5 m	kg	*2.700	*2.700								
	6,0 m	kg	*2.200	1.600		*3.100	2.750					
	4,5 m	kg	*2.050	1.200	3.050	1.650	*3.550	2.700				
	3,0 m	kg	*2.050	1.000	2.950	1.600	*4.450	2.450	*6.700	4.700		
	1,5 m	kg	2.050	950	2.850	1.500	*4.650	2.250				
	0,0 m	kg	2.100	1.000	2.750	1.400	4.450	2.100	*5.300	3.850		
	-1,5 m	kg	2.400	1.150	2.750	1.400	4.400	2.050	*8.600	3.900	*4.550	*4.550
	-3,0 m	kg	3.250	1.600			4.500	2.100	*7.150	4.000		
	 Rear outrigger	7,5 m	kg	*2.700	*2.700							
		6,0 m	kg	*2.200	*2.200		*3.100	*3.100				
4,5 m		kg	*2.050	1.950	*3.250	2.450	*3.550	*3.550				
3,0 m		kg	*2.050	1.700	*3.600	2.350	*4.450	3.850	*6.700	*6.700		
1,5 m		kg	*2.150	1.600	3.600	2.250	*5.350	3.600				
0,0 m		kg	*2.450	1.700	3.500	2.200	5.650	3.450	*5.300	*5.300		
-1,5 m		kg	*2.950	1.900	3.500	2.150	5.600	3.400	*8.600	6.750	*4.550	*4.550
-3,0 m		kg	*3.500	2.600			*4.850	3.450	*7.150	6.900		
 Rear blade		7,5 m	kg	*2.700	*2.700							
		6,0 m	kg	*2.200	1.950		*3.100	*3.100				
	4,5 m	kg	*2.050	1.500	*3.250	1.900	*3.350	3.200				
	3,0 m	kg	*2.050	1.300	*3.600	1.850	*4.450	3.000	*6.700	5.800		
	1,5 m	kg	2.150	1.200	3.750	1.750	5.350	2.750				
	0,0 m	kg	2.450	1.250	3.650	1.650	5.850	2.600	5.300	4.900		
	-1,5 m	kg	2.950	1.450	3.600	1.650	5.750	2.550	8.600	4.950	*4.550	*4.550
	-3,0 m	kg	3.500	1.950			*4.850	2.600	7.150	5.050		
	 Front outrigger + rear blade	7,5 m	kg	*2.700	*2.700							
		6,0 m	kg	*2.200	*2.200		*3.100	*3.100				
4,5 m		kg	*2.050	*2.050	*3.250	2.950	*3.550	*3.550				
3,0 m		kg	*2.050	*2.050	*3.600	2.850	*4.450	*4.450	*6.700	*6.700		
1,5 m		kg	*2.150	2.000	*4.000	2.750	*5.350	4.400				
0,0 m		kg	*2.450	2.050	3.900	2.700	*5.850	4.200	*5.300	*5.300		
-1,5 m		kg	*2.950	2.350	3.900	2.650	*5.750	4.150	*8.600	8.600	*4.550	*4.550
-3,0 m		kg	*3.500	3.150			*4.850	4.250	*7.150	*7.150		

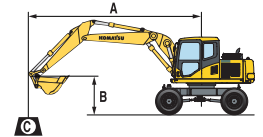

Arm length 2.100 mm

A – Reach from swing center

B – Bucket hook height

C – Lifting capacities, including bucket (462 kg), bucket linkage (84 kg) and bucket cylinder (92 kg)

⊗ – Rating over front

⊗ – Rating over side

⊗ – Rating at maximum reach

When removing bucket, linkage or cylinder, lifting capacities can be increased by their respective weights.

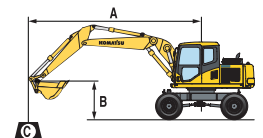

Arm length 2.500 mm

A – Reach from swing center

B – Bucket hook height





C – Lifting capacities, including bucket (462 kg), bucket linkage (84 kg) and bucket cylinder (92 kg)

⊗ – Rating over front

⊗ – Rating over side



⊗ – Rating at maximum reach

When removing bucket, linkage or cylinder, lifting capacities can be increased by their respective weights.

 Without stabilizer	7,5 m	kg	*2.100	*2.100		*3.000	2.750					
	6,0 m	kg	*1.800	1.400	*2.900	1.600						
	4,5 m	kg	*1.650	1.100	*3.000	1.600	*3.200	2.750				
	3,0 m	kg	*1.650	950	3.000	1.550	*4.150	2.550	*5.900	4.950		
	1,5 m	kg	*1.750	850	2.900	1.450	4.700	2.300	6.300	4.200		
	0,0 m	kg	1.950	900	2.800	1.350	4.500	2.100	5.700	3.900		
	-1,5 m	kg	2.200	1.050	2.750	1.300	4.400	2.050	*8.450	3.850	*4.200	*4.200
	-3,0 m	kg	2.800	1.350			4.450	2.100	*7.750	3.950		
	 Rear outrigger	7,5 m	kg	*2.100	*2.100							
		6,0 m	kg	*1.800	*1.800	*2.900	2.500					
4,5 m		kg	*1.650	*1.650	*3.000	2.500	*3.200	*3.200				
3,0 m		kg	*1.650	1.550	*3.400	2.400	*4.150	3.950	*5.900	*5.900		
1,5 m		kg	*1.750	1.500	3.650	2.300	*5.150	3.650	*6.300	*6.300		
0,0 m		kg	*2.000	1.550	3.500	2.200	5.700	3.450	*5.700	*5.700		
-1,5 m		kg	*2.400	1.750	3.500	2.150	5.600	3.400	*8.450	6.750	*4.200	*4.200
-3,0 m		kg	*3.300	2.250			*5.200	3.450	*7.750	8.650		
 Rear blade		7,5 m	kg	*2.100	*2.100							
		6,0 m	kg	*1.800	1.700	*2.900	1.950					
	4,5 m	kg	*1.650	1.350	*3.000	1.950	*3.200	*3.200				
	3,0 m	kg	*1.650	1.200	*3.400	1.900	*4.150	3.100	*5.900	*5.900		
	1,5 m	kg	*1.750	1.100	3.750	1.750	*5.150	2.800	*6.300	5.300		
	0,0 m	kg	*2.000	1.150	3.650	1.700	*5.800	2.650	*5.700	4.950		
	-1,5 m	kg	*2.400	1.300	3.600	1.650	*5.850	2.550	*8.450	4.900	*4.200	*4.200
	-3,0 m	kg	*3.300	1.700			*5.200	2.600	*7.750	5.000		
	 Front outrigger + rear blade	7,5 m	kg	*2.100	*2.100							
		6,0 m	kg	*1.800	*1.800			*2.900	*2.900			
4,5 m		kg	*1.650	*1.650	*3.000	3.000	*3.200	*3.200				
3,0 m		kg	*1.650	*1.650	*3.400	2.900	*4.150	*4.150	*5.900	*5.900		
1,5 m		kg	*1.750	*1.750	*3.850	2.800	*5.150	4.450	*6.300	*6.300		
0,0 m		kg	*2.000	1.900	3.900	2.700	*5.800	4.250	*5.700	*5.700		
-1,5 m		kg	*2.400	2.150	3.900	2.650	*5.850	4.200	*8.450	*8.450	*4.200	*4.200
-3,0 m		kg	*3.300	2.700								

* Load is limited by hydraulic capacity rather than tipping. Ratings are based on SAE Standard No. J1097. Rated loads do not exceed 87% of hydraulic lift capacity or 75% of tipping load.

TWO-PIECE BOOM + ROTATING ARM

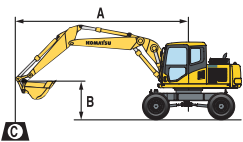

Arm length	A	⊗		7,5 m		6,0 m		4,5 m		3,0 m		1,5 m		
		⌋	⌋	⌋	⌋	⌋	⌋	⌋	⌋	⌋	⌋	⌋	⌋	
B		⌋	⌋	⌋	⌋	⌋	⌋	⌋	⌋	⌋	⌋	⌋	⌋	
 <p>Front outrigger + rear blade</p>	7,5 m	kg	*1.950	*1.950										
	6,0 m	kg	*1.600	*1.600		*2.600	*2.600							
	4,5 m	kg	*1.500	*1.500		*2.650	*2.650	*2.850	*2.850					
	3,0 m	kg	*1.500	*1.500	*2.300	1.700	*3.000	2.650	*3.700	*3.700	*5.300	*5.300		
	1,5 m	kg	*1.600	1.550	2.550	1.650	*3.450	2.500	*4.600	4.050	*6.850	*6.850		
	0,0 m	kg	*1.750	1.600	*2.200	1.600	3.600	2.350	*5.250	3.800	*5.700	*5.700		
	-1,5 m	kg	*2.100	1.800			3.550	2.300	*5.300	3.700	*8.250	7.750	*4.000	*4.000
	-3,0 m	kg	*2.900	2.350			*3.100	2.400	*4.750	3.750	*7.150	*7.150	*7.200	*7.200
	 <p>Outrigger front + rear</p>	7,5 m	kg	*1.950	*1.950									
		6,0 m	kg	*1.600	*1.600		*2.600	*2.600						
4,5 m		kg	*1.500	*1.500		*2.650	*2.650	*2.850	*2.850					
3,0 m		kg	*1.500	*1.500	*2.300	*2.300	*3.000	*3.000	*3.700	*3.700	*5.300	*5.300		
1,5 m		kg	*1.600	*1.600	2.400	2.300	*3.450	3.400	*4.600	*4.600	*6.850	*6.850		
0,0 m		kg	*1.750	*1.750	*2.200	*2.200	3.450	2.350	*5.250	*5.250	*5.700	*5.700		
-1,5 m		kg	*2.100	*2.100			3.550	2.300	*5.300	5.200	*8.250	*8.250	*4.000	*4.000
-3,0 m		kg	*2.900	*2.900			*3.100	*3.100	*4.750	*4.750	*7.150	*7.150	*7.200	*7.200



Arm length 2.600 mm

- A – Reach from swing center
- B – Bucket hook height
- C – Lifting capacities, including bucket (462 kg), bucket linkage (84 kg) and bucket cylinder (92 kg)

When removing bucket, linkage or cylinder, lifting capacities can be increased by their respective weights.

-  – Rating over front
-  – Rating over side
-  – Rating at maximum reach

HYDRAULIC WHEELED EXCAVATOR



STANDARD EQUIPMENT

- | | | | |
|--|--|--|--|
| <ul style="list-style-type: none"> • Komatsu SAA4D102E-2 78 kW direct injection emissionised Stage II intercooled turbocharged engine • Double element type air cleaner with dust indicator and auto dust evacuator • Suction type cooling fan • Automatic fuel line de-aeration • Engine key stop • Engine ignition can be password secured on request • Engine overheat prevention system • Auto-deceleration function • Automatic engine warm-up system • Alternator 24 V/40 A • Batteries 2 × 12 V/95 Ah • Starter motor 24 V/5,5 kW • Standard counterweight • Electronic closed-centre load sensing (E-CLSS) hydraulic system (HydrauMind) | <ul style="list-style-type: none"> • Pump and engine mutual control (PEMC) system • Multi-function colour monitor with equipment management monitoring system (EMMS) • 4-working mode selection system; Active mode, economy mode, breaker mode and lifting mode • PowerMax function • Adjustable PPC wrist control levers for arm, boom, bucket and swing • One additional 2-way service valve (full flow) • Fully automatic 3-speed transmission driving through front and rear planetary axles • Orbitrol type hydraulic steering acting on front wheels • Oscilating front axle (7°) with automatic and manual cylinder locking | <ul style="list-style-type: none"> • Dual circuit hydraulic brakes with outboard wet multi-disc service brakes • Spring actuated park brake (hydraulic release) incorporated into transmission • SpaceCab™, highly pressurized and tightly sealed viscous mounted cab with tinted safety glass windows, pull-up type front window with locking device, removable lower window, front window wiper with intermittent feature, sun blind roller, magazine rack behind seat, 12 V power supply, cigarette lighter, ashtray, floor mat, machine cab handrails, suspension seat with tiltable left hand console, automatic weight adjustment, adjustable arm rests and retractable seat belt, hot and cool box | <ul style="list-style-type: none"> • Parts book and operator manual • Lockable fuel cap and covers • Fuel supply pump • Overload warning device • Boom safety valves • Climate control/Air conditioning • Radio cassette preparation • Toolkit and spare parts for first service • Single chassis tool box • Standard colour scheme and decals • Four sets of tyre and rim (twin tyre) 10.00-20 14 PR |
|--|--|--|--|

OPTIONAL EQUIPMENT

- | | | | |
|--|---|--|--|
| <ul style="list-style-type: none"> • Mono boom • Two-piece boom • 2,1 m; 2,5 m arms • 2,6 m rotating arm • Parallel blade (front and/or rear) • 2 or 4 outriggers with cylinder protection • Four sets of tyre and rim (single tyre) 18.00-19.5 | <ul style="list-style-type: none"> • Nokian twin tyres 10-20 • Bandenmarkt twin tyres type grader 315/80 R 22.5 • Komatsu quick couplers • Komatsu buckets • Transmission guard • Clamshell grip bar • Cold weather battery 120 Ah • Adjust cylinder safety valve | <ul style="list-style-type: none"> • Arm cylinder safety valve • Heated air suspension seat • Radio-cassette • OPG Level II front guard (FOPS) • Additional RH boom lamp • Beacon + rear facing cab lamp • Additional large capacity cab roof lights (2) • Bio oil | <ul style="list-style-type: none"> • Dozer blade cylinder guard • Rain visor (not for use with OPG) • Additional chassis tool box • Customized paint |
|--|---|--|--|

KOMATSU®

Komatsu Europe International NV

Mechelsesteenweg 586
 B-1800 VILVOORDE (BELGIUM)
 Tel. +32-2-255 24 11
 Fax +32-2-252 19 81
 www.komatsueurope.com

UESS10300 04/2005

Materials and specifications are subject to change without notice.

KOMATSU® is a trademark of Komatsu Ltd. Japan.