



TIMBERWOLF[®]

THE CHIP & SHRED EXPERTS



TW 150VTR/FTR INSTRUCTION MANUAL



timberwolf-uk.com

© Copyright Entec Industries Ltd 2015

The content of this publication may not be copied, reproduced, republished, posted, broadcast, transmitted or used in any way in any medium without the written permission of Entec Industries Ltd.



<i>Section</i>	<i>Page No.</i>
INTRODUCTION	1
PURPOSE OF MACHINE	2
MACHINE DIMENSIONS & SPECIFICATIONS	2
PARTS LOCATION DIAGRAMS	3
SAFE WORKING	5
Operator's Personal Protective Equipment Required	5
Basic Woodchipping Safety	5
General Safety Matters - Do's and Don'ts	6
Noise Test	7
OPERATING INSTRUCTIONS	8
Delivery	8
Operator's Personal Protective Equipment Required	8
Manual Controls	8
Crawler Track Controls	9
Auto Controls	9
Emergency Stopping	9
Daily Checks Before Starting	10
Engine Controls	10
Starting the Engine	10
Controlling the Engine Speed	10
Stopping the Engine	10
Before Using the Chipper	11
Starting to Chip	11
Chipping	11
Blockages	12
Removing the Funnel	12
Chassis Jacking Point	12
Discharge Controls	13
Hydraulic oil level indicator	13
Fuel Level Indicator	13
Blade Wear	13
SERVICE INSTRUCTIONS	14
Service Schedule	15
Safe Maintenance	16
Engine Servicing	16
Spares	16
Safe Lifting & Securing down of the Chipper	16
Battery Removal and Maintenance	16
Copper Ease Safety Information	17
Battery Safety Information	17
Change Hydraulic Oil and Filter	19
Check Fittings	19
Check Hoses	19
Change Blades	20
Tension Belts	21
Grease the Discharge Flange	21
Grease the Roller Spline and Bearing	21
Grease the Roller Box Slides	22
Greasing Rotor Bearings	22
Track Base Maintenance	22
Lubricate Variable Track Base Slides	22
Replace Oil in Track Drive Unit	23
Draining the Oil in the Track Drive Unit	23
Reduction Unit Oil Types	23
Checking the Rubber Tracks	23
Checking Track Tension	24
Track Loosening / Tightening Procedures	24
Removing the Rubber Tracks	25
Installing the Rubber Tracks	25
Checking Sprocket Wear	25
WARRANTY STATEMENT	26
EC DECLARATION OF CONFORMITY CERTIFICATE	27
IDENTIFICATION PLATES	28
DECALS	29
ELECTRICAL DETAILS	31
CIRCUIT DIAGRAM	32
HYDRAULIC LAYOUT	33
PARTS LISTS	36



INTRODUCTION

Thank you for choosing Timberwolf. Timberwolf chippers are designed to give safe and dependable service if operated according to the instructions.

IMPORTANT HEALTH AND SAFETY INFORMATION

Before using your new chipper, please take time to read this manual. Failure to do so could result in:

- PERSONAL INJURY
- EQUIPMENT DAMAGE
- DAMAGE TO PROPERTY
- 3RD PARTY INJURIES

This manual covers the operation and maintenance of the Timberwolf TW 150VTR/FTR. All information in this manual is based on the latest product information available at the time of purchase.

All the information you need to operate the machine safely and effectively is contained. Ensure that all operators are **properly trained** for operating this machine, especially **safe working practices**.

Timberwolf's policy of regularly reviewing and improving their products may involve major or minor changes to the chippers or their accessories. Timberwolf reserves the right to make changes at any time without notice and without incurring any obligation.

Due to improvements in design and performance during production there may be, in some cases, minor discrepancies between the actual chipper and the text in this manual.

The manual should be considered an important part of the machine and should remain with it if the machine is resold.

ALWAYS FOLLOW SAFE OPERATING AND MAINTENANCE PRACTICES



CAUTION or WARNING

BE AWARE OF THIS SYMBOL AND WHERE SHOWN, CAREFULLY FOLLOW THE INSTRUCTIONS.

This caution symbol indicates important safety messages in this manual. When you see this symbol, be alert to the possibility of injury to yourself or others and carefully read the message that follows.



The Timberwolf TW 150VTR/FTR

Designed to chip solid wood material up to 150mm in diameter and capable of chipping up to 4 tonnes of brushwood per hour.

DIMENSIONS

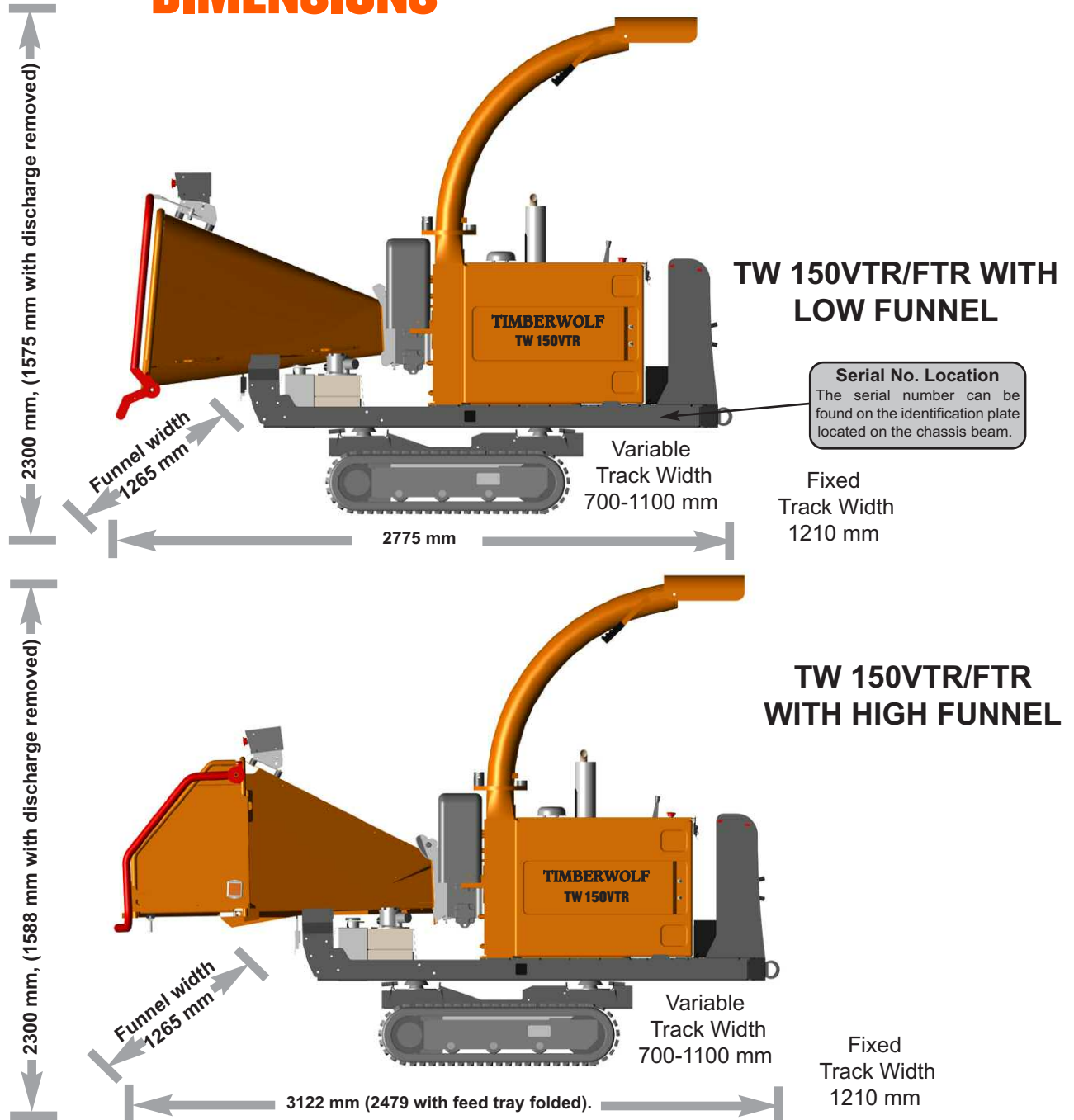

TIMBERWOLF TW 150VTR/FTR SPECIFICATION

Engine type	<i>Kubota 4-cylinder diesel</i>	Maximum diameter material	150 mm (6")
Maximum power	26kW (35hp)	Fuel capacity	18 litres
Cooling method	<i>Water cooled</i>	Hydraulic oil capacity	15 litres
Overall weight	1080kg(VTR) 1120kg (FTR)	Material processing capacity	4 tonnes/hr
Starting method	<i>Electric</i>	Fuel type	<i>Diesel</i>
Roller feed	<i>Twin series hydraulic motors</i>		



PARTS LOCATOR

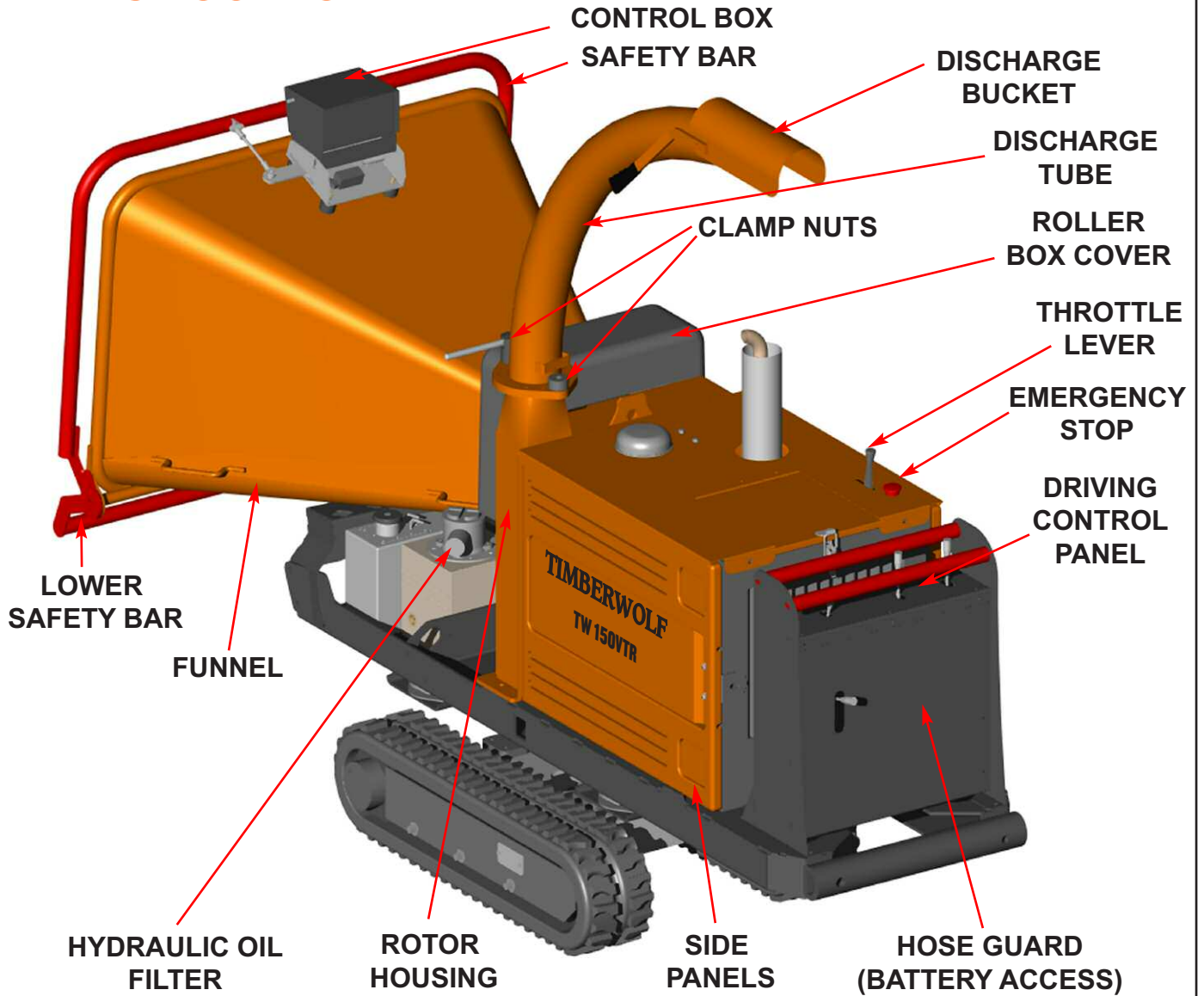

TW 150VTR/FTR WITH HIGH FUNNEL

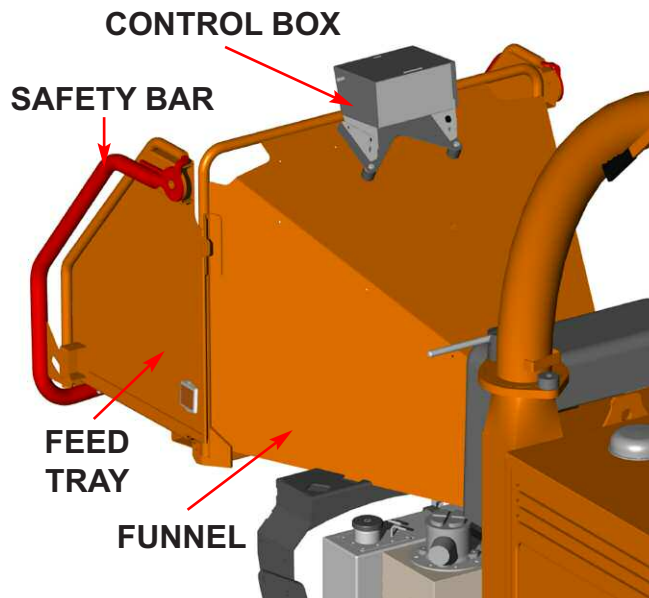



PARTS LOCATOR

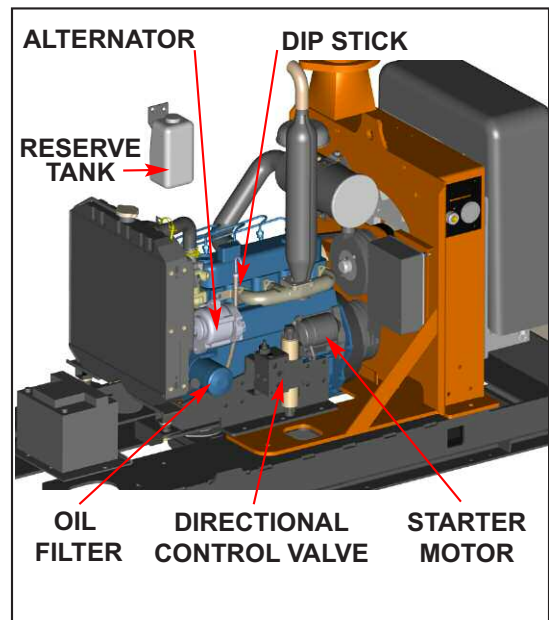
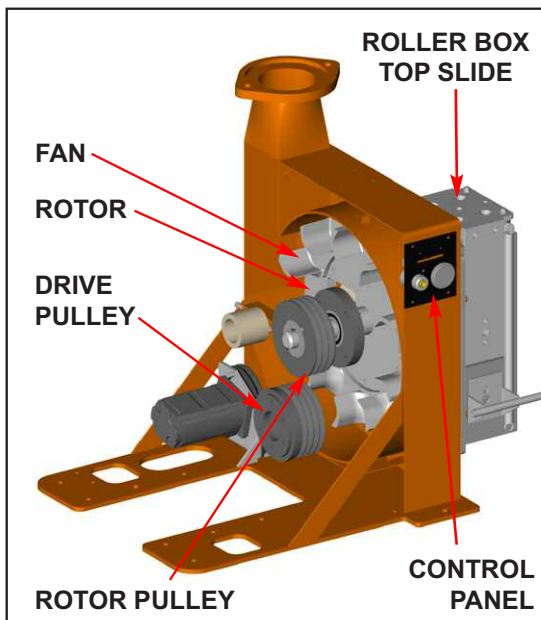
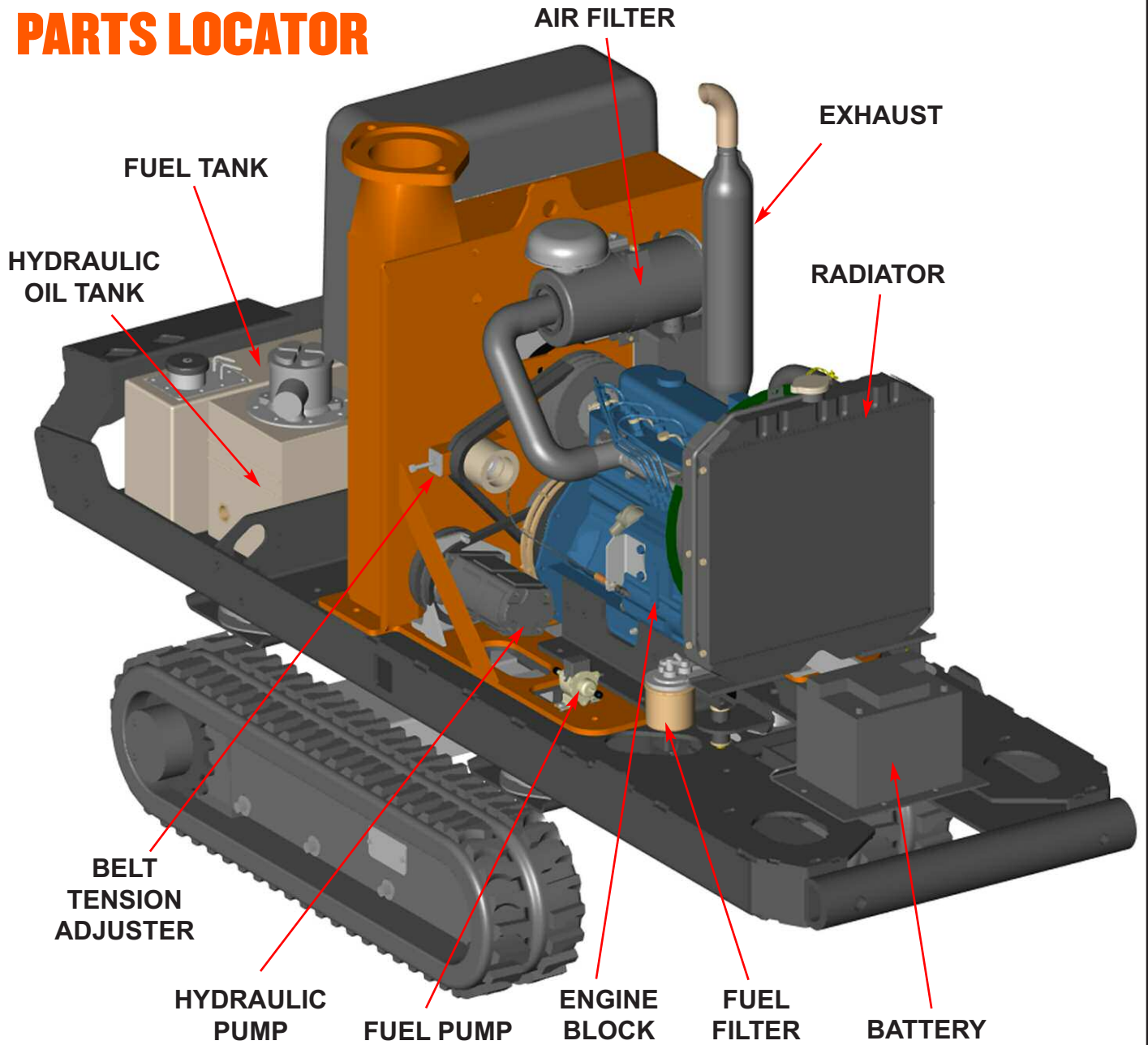



WARNING

The chipper will feed material through on its own. To do this, it relies on sharp blades both on the feed rollers and the chipper rotor. To keep the blades sharp, only feed the machine with clean brushwood. **DO NOT** put muddy/dirty wood, roots, potted plants, bricks, stones or metal into the chipper.



OPERATOR'S PERSONAL PROTECTIVE EQUIPMENT REQUIRED



Chainsaw safety helmet fitted with mesh visor and recommended ear defenders to the appropriate specifications.



Close fitting heavy-duty non-snag clothing.



Work gloves with elasticated wrist.



Face mask if appropriate.



Steel toe cap safety boots.



DO NOT wear rings, bracelets, watches, jewellery or any other items that could be caught in the material and draw you into the chipper.

BASIC WOODCHIPPING SAFETY

The operator should be aware of the following points:

- **MAINTAIN A SAFETY EXCLUSION ZONE** around the chipper of at least 10 metres for the general public or employees without adequate protection. Use hazard tape to identify this working area and keep it clear from debris build up. Chips should be ejected away from any area the general public have access to.
- **HAZARDOUS MATERIAL** - Some species of trees and bushes are poisonous. The chipping action can produce vapour, spray and dust that can irritate the skin. This may lead to respiratory problems or even cause serious poisoning. Check the material to be chipped before you start. Avoid confined spaces and use a facemask if necessary.
- **BE AWARE** when the chipper is processing material that is an awkward shape. The material can move from side to side in the funnel with great force. If the material extends beyond the funnel, the brush may push you to one side causing danger. Badly twisted brush should be trimmed before being chipped to avoid thrashing in the feed funnel.
- **BE AWARE** that the chipper can eject chips out of the feed funnel with considerable force. Always wear full head and face protection.
- **ALWAYS** work on the side of the machine furthest from any local danger, e.g. not road side.



GENERAL SAFETY MATTERS



DO'S AND DON'TS



ALWAYS stop the chipper engine before making any adjustments, refuelling or cleaning.

ALWAYS check rotor has stopped rotating and remove chipper ignition key before maintenance of any kind, or whenever the machine is to be left unattended.

ALWAYS check the machine is well supported and cannot move.

ALWAYS operate the chipper with the engine set to maximum speed when chipping.

ALWAYS check (visually) for fluid leaks.

ALWAYS take regular breaks. Wearing personal protective equipment for long periods can be tiring and hot.

ALWAYS keep hands, feet and clothing out of feed opening, discharge and moving parts.

ALWAYS use the next piece of material or a push stick to push in short pieces. Under no circumstances should you reach into the funnel.



ALWAYS keep the operating area clear of people, animals and children.

ALWAYS keep the operating area clear from debris build up.

ALWAYS keep clear of the chip discharge tube. Foreign objects may be ejected with great force.

ALWAYS ensure protective guarding is in place before commencing work. Failure to do so may result in personal injury or loss of life.

ALWAYS operate the chipper in a well ventilated area - exhaust fumes are dangerous.

DO NOT operate chipper unless available light is sufficient to see clearly.

DO NOT use or attempt to start the chipper without the feed funnel, guards and discharge unit securely in place.

DO NOT stand directly in front of the feed funnel when using the chipper. Stand to one side.

DO NOT allow -



BRICKS STRING CLOTH PLASTIC STONES



METAL GLASS RUBBER ROOTS BEDDING PLANTS

- to enter the machine, as damage is likely.

DO NOT smoke when refuelling.



DO NOT let anyone who has not received instruction operate the machine.

DO NOT climb on the machine at any time.

DO NOT handle material that is partially engaged in the machine.

DO NOT touch any exposed wiring while machine is running.

DO NOT use the chipper inside buildings.

WARNING

NEVER LEAVE THE CHIPPER ON A SLOPE UNATTENDED.





NOISE TEST

MACHINE: TW 150VTR/FTR

NOTES: Tested chipping 120mm x 120mm corsican pine 1.5m in length

Noise levels above 80dB (A) will be experienced at the working position. Wear ear protection at all times to prevent possible damage to hearing. All persons within a 4 metre radius must also wear good quality ear protection.

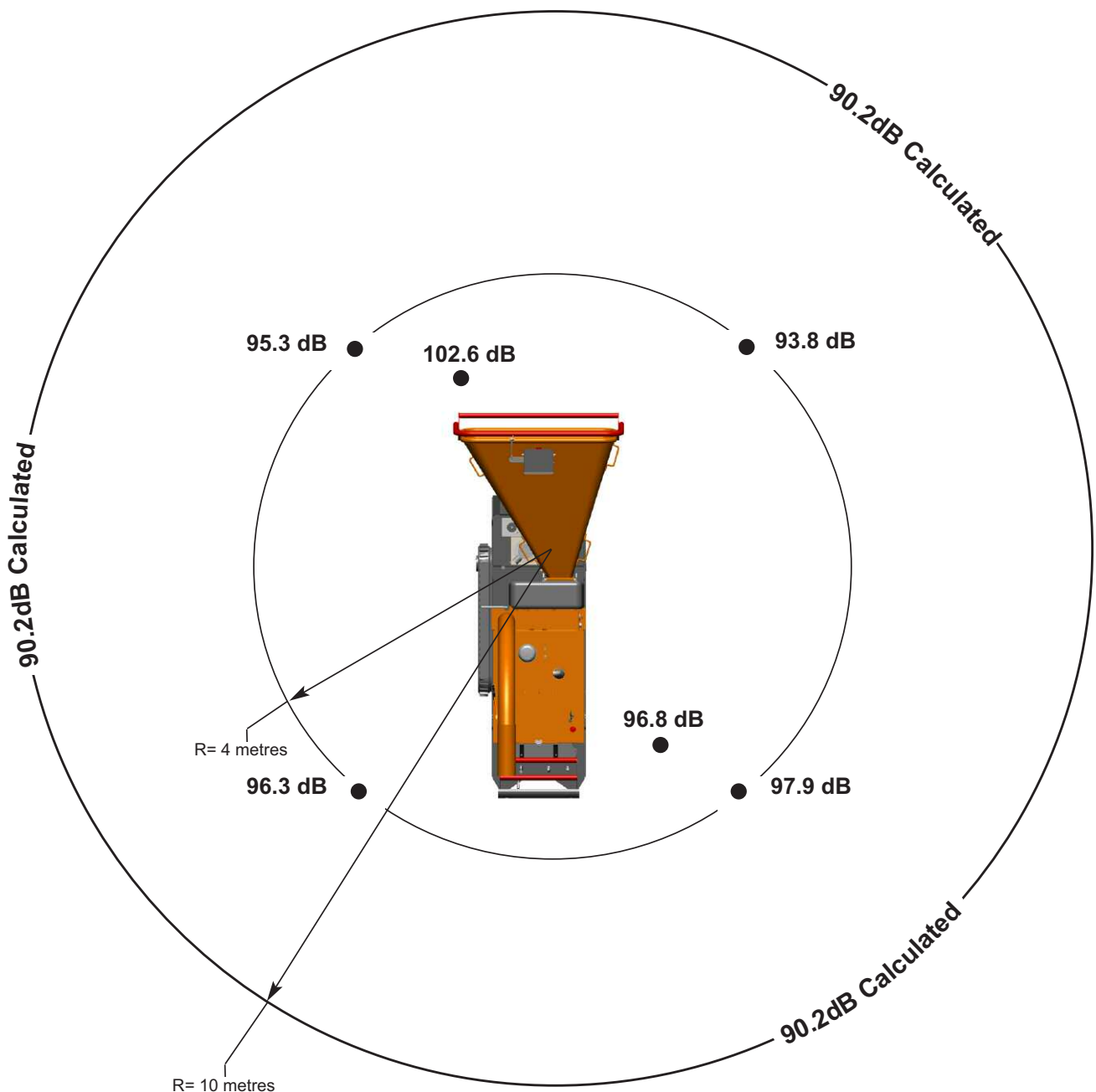

Guaranteed Sound Power: 119dB (A)

As required by Annex III of Directive 2000/14/EC "Noise Emission in the environment by equipment for use outdoors".



DELIVERY

All Timberwolf TW 150VTR/FTR machines have a full pre - delivery inspection before leaving the factory and are ready to use. Read and understand this instruction manual before attempting to operate the chipper. In particular, read pages 5-7 which contain important health and safety information and advice.

OPERATOR'S PERSONAL PROTECTIVE EQUIPMENT REQUIRED

- CHAINSAW safety helmet fitted with visor and recommended ear defenders to an appropriate specification.
- HEAVY-DUTY gloves with elasticated wrist area.
- CLOSE - FITTING heavy-duty non-snag clothing.
- SAFETY footwear.
- FACE MASK (if appropriate).

See page 5 for more detailed information.

MANUAL CONTROLS

Roller control box - is the control box above the feed opening of the chipper funnel. Its function is to control the feed rollers. The feed rollers draw material into the machine. **It does not control the main rotor.**

RED SAFETY BAR = This is the large red bar that surrounds the sides and top of the feed funnel (sides and bottom on high funnel). The bar is spring loaded and connected to a switch that will interrupt the power to the rollers. The switch is designed so that it only activates if the bar is pushed (pushed or pulled...low funnel only) to the limit of its travel. The rollers stop instantly, but can be made to turn again by pressing either the **GREEN FEED** or **BLUE REVERSE** control buttons.

LOW SAFETY BAR = An additional safety bar is located along the bottom of the low funnel. This is linked directly to the main bar, and will stop the rollers if pushed *only*. Pulling this bar will only move it into its 'stowed' (up) position.

GREEN BUTTON = Forward feed - Push the button once - this activates the rollers and will allow you to start chipping (if the rotor speed is high enough).

RED BUTTON = Emergency stop - This button stops the rollers from feeding. It overrides all other buttons or bars and will not allow the other buttons to function until it has been reset. Pull the button out to reset, the forward and reverse buttons will now function.

BLUE BUTTON = Reverse feed - allows you to back material out of the rollers. The rollers will only turn in reverse as long as you keep pressing the button. You do not have to press the STOP button before pressing the **GREEN FEED** button to recommence feeding. **NOTE: This reverse function will work even if the safety bar is pushed or pulled.**

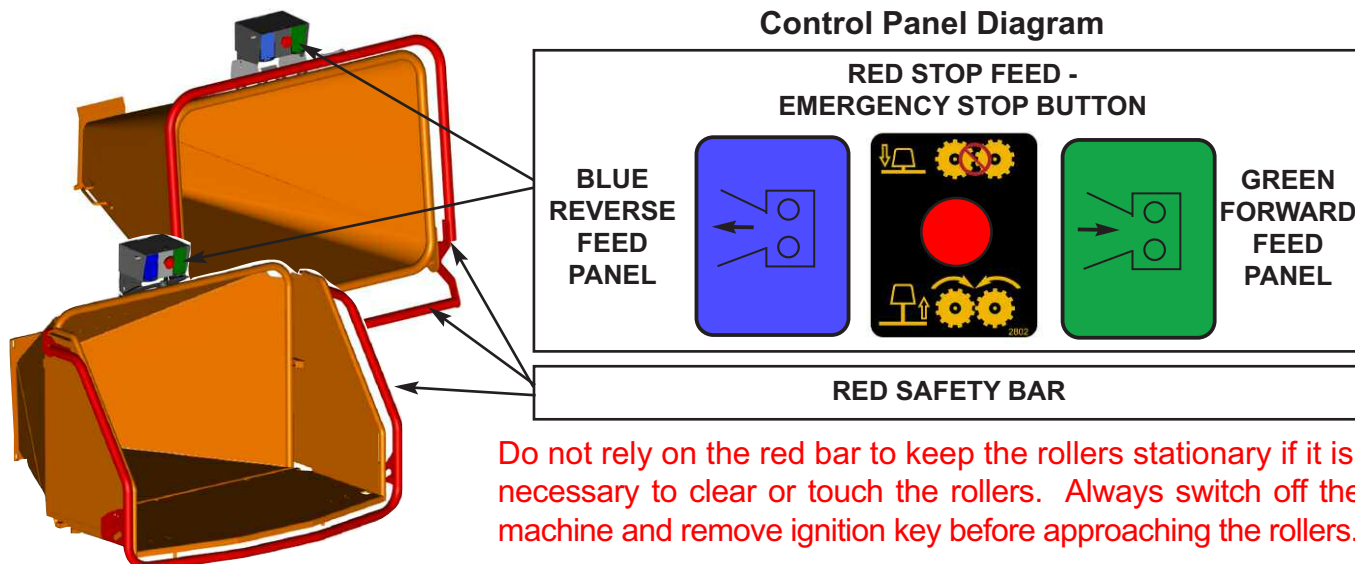

Do not rely on the red bar to keep the rollers stationary if it is necessary to clear or touch the rollers. Always switch off the machine and remove ignition key before approaching the rollers.



CRAWLER TRACK CONTROLS

WARNING

NEVER LEAVE THE CHIPPER ON A SLOPE UNATTENDED.



The chipper is designed to operate in either chipper or crawler mode, but not both at the same time.

CHIPPING MODE

Power is available to the feed rollers. The cutting disc is rotating but the unit is stationary.

CRAWLER TRACK MODE

Power is available to the crawler tracks. The cutting disc is rotating but the feed rollers are stationary.

To switch between modes, a lever is operated (see diagram below). This is located on the driving control panel (see parts locator on page 3). It is clearly marked.

When Track mode is selected the two track control valves may be operated. These have direct control over the track relevant to each side of the machine. They are proportional valves, so increased movement will result in increased track speed.

Tracking may be done at either high or low engine speed. Manoeuvring the machine in tight spaces and while loading and unloading should be done with the engine on low speed.

NOTE: Ensure low safety bar on low funnel is rotated into the 'stowed' (up) position prior to tracking to avoid damage to the bar.



For machines fitted with variable tracks, track width adjustment is only possible with the track/chip control in the chip position. Track adjust handle is spring loaded to the middle (see diagram, right). The more you move the handle, the more the tracks adjust. To move the tracks outward, move the track adjust handle *up*. To bring tracks inward, move the track adjust handle *down*.

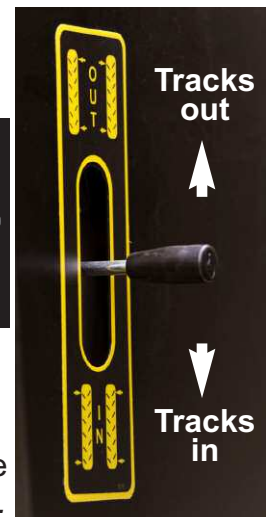

AUTO CONTROLS

The engine management unit controls the feed rate of the material going into the chipping chamber. If the engine speed is below the predetermined level, the engine management unit will not allow the feed rollers to work in the forward feed direction, until the rotor speed rises above the predetermined level. At this point the feed rollers will start turning without warning. The reverse function will work at any speed.

EMERGENCY STOPPING

There are three ways of stopping the TW 150VTR/FTR chipper in the event of an emergency.

STOPPING THE ROLLERS

-Activating the red safety bar will stop the rollers immediately. To restart the rollers, just push the green forward button or blue reverse button.

-Pushing the red Emergency button on the roller control box will also stop the rollers immediately. The button will stay in the "pushed in" position, and will require resetting (pulling out) before being able to restart the roller functions.

STOPPING THE ENGINE

Should the entire machine need to be stopped in an emergency, the red button on top of the engine guard should be pushed. This will shut down the engine in the shortest possible time. The engine cannot be restarted until the button is pulled out and the main ignition switch is turned off to reset the machine.



DAILY CHECKS BEFORE STARTING

- LOCATE the machine on firm level ground.
 - CHECK machine is well supported and cannot move.
 - CHECK jack stand is lowered and secure.
 - CHECK all guards are fitted and secure.
 - CHECK the discharge unit is in place and fastened securely.
 - CHECK discharge tube is pointing in a safe direction.
 - CHECK the feed funnel to ensure no objects are inside.
 - CHECK feed tray is in up position - to prevent people reaching rollers.
 - CHECK controls as described on page 11.
 - CHECK (visually) for fluid leaks.
 - CHECK fuel and hydraulic oil levels.
- For parts location see diagrams on pages 3 & 4.*

ENGINE CONTROLS

The engine controls are in two locations. The engine ignition is on the control panel in the centre of the machine, and the throttle lever is on the bonnet next to the engine emergency stop switch (see parts locator on page 4).

STARTING THE ENGINE

- ENSURE throttle lever is in the slow (tortoise) position.
- INSERT key. Turn to heat.
- HEATER LED comes on.
- WAIT FOR HEATER LED TO GO OUT.
- TURN key to engage starter motor.
- RELEASE key once engine starts.

Do not engage starter motor for more than 20 seconds - allow one minute before attempting to start. Investigate reasons for failure to start.



HOURS COUNTER

When the emergency stop button is pressed it must be pulled out again and the ignition switch turned off to reset the machine before attempting to restart.

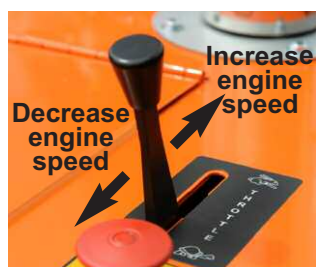

CONTROLLING ENGINE SPEED

The engine has two throttle settings, idle and fast. These are controlled by the throttle lever on the bonnet. Moving the lever towards the 'Hare' on the pictogram will increase engine speed while moving it towards the 'Tortoise' will decrease the engine speed.

STOPPING THE ENGINE

- MOVE the throttle lever to the 'Tortoise' to reduce the engine speed to idle.
- LEAVE the engine running for 1 minute.
- TURN the power switch to position 0. The engine should stop after a few seconds.
- REMOVE the ignition key.

FUEL LEVEL INDICATOR

The fuel level can be seen through the wall of the plastic tank.



BEFORE USING THE CHIPPER

IT IS ESSENTIAL TO CARRY OUT THE FOLLOWING TESTS to check safety equipment - this sequence of tests will only take a few seconds to carry out. We recommend that these tests are carried out daily. Observing the function as described will confirm that the safety circuits are working correctly. This is also a good opportunity to remind all operators of the control and emergency stop systems.

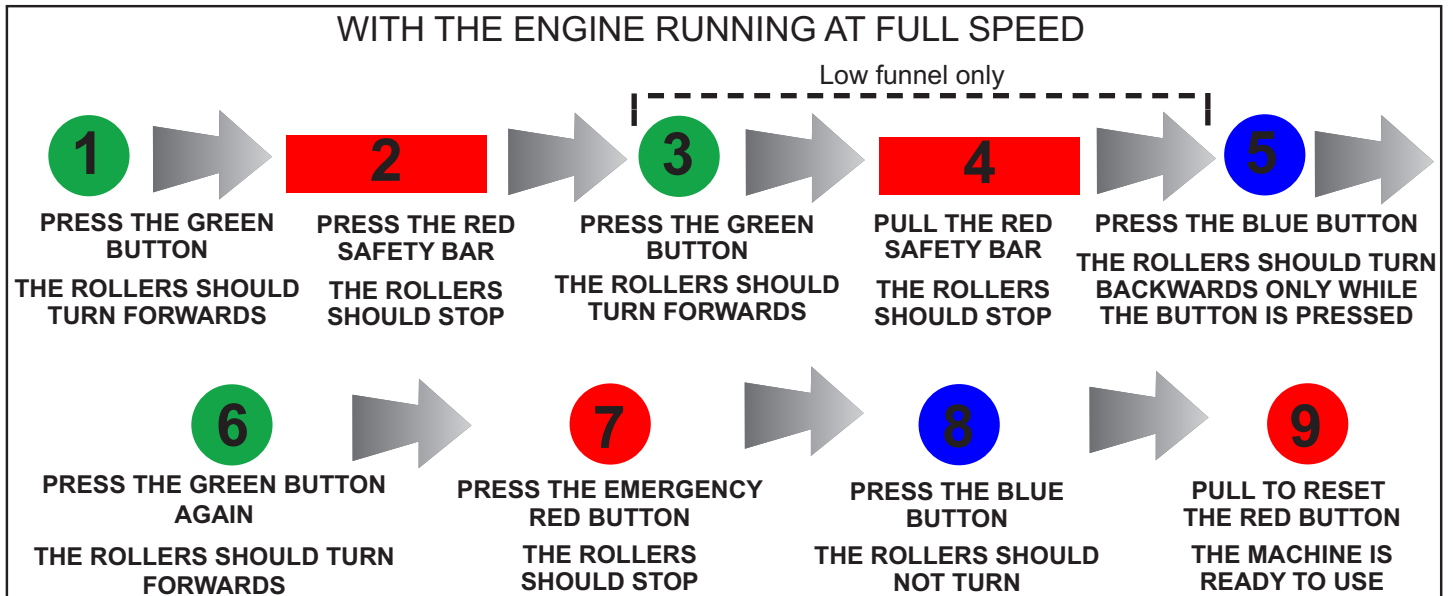

STARTING TO CHIP

WARNING

Do not use or attempt to start the chipper without the protective guarding and discharge unit securely in place. Failure to do so may result in personal injury or loss of life.



- CHECK that chipper is running smoothly.
- PULL to release the red emergency stop button.
- PRESS the green control button. The rollers will commence turning.
- STAND to one side of the feed funnel.
- PROCEED to feed material into the feed funnel.

CHIPPING

Wood up to the recommended diameter can be fed into the feed funnel. Put the butt end in first and engage it with the feed rollers. The hydraulic feed rollers will pull the branch into the machine quite quickly. Large diameter material will have its feed rate automatically controlled by the no stress unit.

Sometimes a piece of wood that is a particularly awkward shape is too strong for the feed rollers to break. This will cause the top roller to either bounce up and down on the wood, or both rollers to stall. If this occurs, press the **BLUE REVERSE** button until the material has been released. Pull the material out of the feed funnel and trim it so the chipper can handle it.

Both feed rollers should always turn at the same speed. If one or both rollers stop or suddenly slow down it may be that a piece of wood has become stuck behind one of the rollers. If this occurs, press the **BLUE REVERSE** button and hold for 2 seconds - then repress **GREEN FEED** button. This should enable the rollers to free the offending piece of material and continue rotating at the correct speed. If the rollers continue to stall in the 'forward feed' or 'reverse feed' position push the **RED STOP BUTTON**, turn the engine off, remove the ignition key and investigate.



BLOCKAGES

Always be aware that what you are putting into the chipper must come out. If the chips stop coming out of the discharge tube but the chipper is taking material in - STOP IMMEDIATELY. Continuing to feed the chipper with brushwood once it has become blocked will cause the chipper to compact the chips in the rotor housing and it will be difficult and time consuming to clear.

AVOID THIS SITUATION - WATCH THE DISCHARGE TUBE AT ALL TIMES.

If the chipper becomes blocked, proceed as follows:

- STOP the engine and remove the ignition keys.
- REMOVE the discharge tube. Check that it is clear.
- WEARING gloves, reach into the rotor housing and scoop out the majority of the debris causing the blockage.

WARNING

Do not reach into the rotor housing with unprotected hands. There are sharp blades and any small movement of the rotor may cause serious injury.



- REPLACE the discharge tube.
- RESTART the engine and increase to full speed.
- ALLOW machine time to clear excess chips still remaining in rotor housing before you continue feeding brushwood. Feed in a small piece of wood while watching to make sure that it comes out of the discharge. If this does not clear it, repeat the process and carefully inspect the discharge tube to find any obstruction.

REMOVING THE FUNNEL

1. DISCONNECT the control box loom from the engine loom at the connection point location under the near side of the funnel.
- 2a. ON the high funnel / tray, ensure tray is closed and catches are latched.
- 2b. ON the low funnel, rotate low safety bar into its 'stowed' (up) position.
3. RELEASE the two catches that secure the funnel to the chassis, located underneath funnel. (Only one catch on high funnel).
4. WITH two people in position, lift the funnel by the handles (if fitted), ensure the wide end is lifted first then release the narrow end from the roller box assembly.

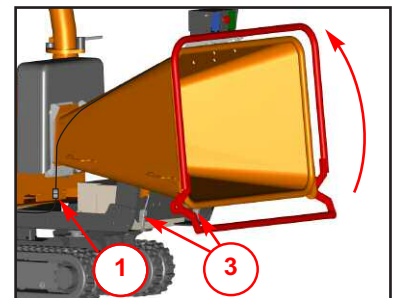

CHASSIS JACKING POINT

1. LOOSEN the cover plate bolt on the appropriate side of the chipper.
2. ROTATE cover plate, allowing it to remain attached to the chassis.
3. PULL the jacking beam from the access hole to its fullest extent (approx 300 mm).
4. AFTER use, push beam back into access hole and secure cover plate.

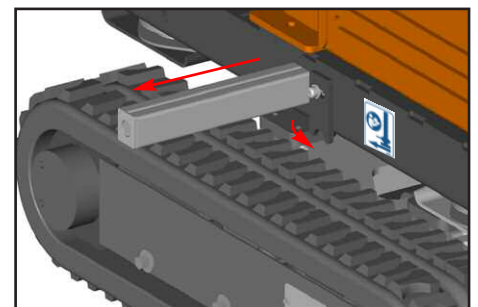



DISCHARGE CONTROLS

Controlling the discharge is an essential part of safe working.

ROTATION

1. Slacken nut using integral handle.
2. Rotate tube.
3. Retighten nut.

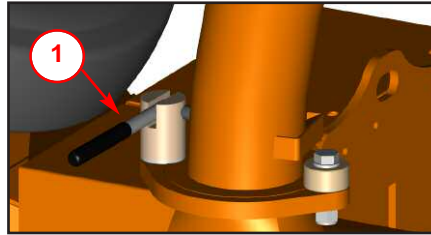

BUCKET ANGLE

4. Adjust the bucket to the desired angle using the handle provided.

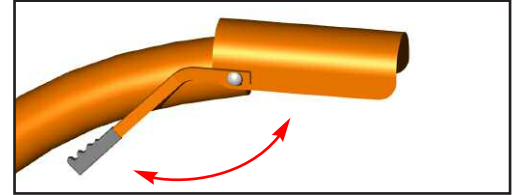

HYDRAULIC OIL LEVEL INDICATOR

The oil level will be visible through the tank wall. It should be within the upper and lower level marks.

FUEL LEVEL INDICATOR

The fuel level can be seen through the wall of the plastic tank.

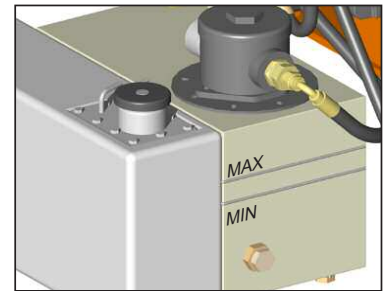

BLADE WEAR

The most important part of using a wood chipper is keeping the cutter blades sharp. Timberwolf chipper blades are hollow ground to an angle of 40 degrees. When performing daily blade checks ensure blade edge is sharp and free from chips, if there is any evidence of damage, or the edge is "dull" change the blade(s). The TW 150VTR/FTR is fitted with 2 blades 101mm (4") long. They are 44 mm wide when new. A new blade should chip for up to 25 hours before it requires sharpening. This figure will be drastically reduced by feeding the machine with stony, sandy or muddy material.

As the blade becomes blunt, performance is reduced. With increased stress and load on the machine the chips will become more irregular and stringy. At this point the blade should be sent to a reputable blade sharpening company. The blade can be sharpened several times in its life. A wear mark on the reverse side indicates the safe limit of blade wear. Replace when this line is exceeded.

The machine is also fitted with a static blade (anvil). It is important that the anvil is in good condition to allow the cutting blades to function efficiently. Performance will be poor, even with sharp cutter blades, if the anvil is worn.



**THE FOLLOWING PAGES DETAIL ONLY
BASIC MAINTENANCE GUIDELINES SPECIFIC
TO YOUR CHIPPER.**



THIS IS NOT A WORKSHOP MANUAL.

THE FOLLOWING GUIDELINES ARE NOT EXHAUSTIVE AND DO NOT EXTEND TO GENERALLY ACCEPTED STANDARDS OF ENGINEERING/MECHANICAL MAINTENANCE THAT SHOULD BE APPLIED TO ANY PIECE OF MECHANICAL EQUIPMENT AND THE CHASSIS TO WHICH IT IS MOUNTED.

AUTHORISED TIMBERWOLF SERVICE AGENTS ARE FULLY TRAINED IN ALL ASPECTS OF TOTAL SERVICE AND MAINTENANCE OF TIMBERWOLF WOOD CHIPPERS. YOU ARE STRONGLY ADVISED TO TAKE YOUR CHIPPER TO AN AUTHORISED AGENT FOR ALL BUT THE MOST ROUTINE MAINTENANCE AND CHECKS.

TIMBERWOLF ACCEPTS NO RESPONSIBILITY FOR THE FAILURE OF THE OWNER/USER OF TIMBERWOLF CHIPPERS TO RECOGNISE GENERALLY ACCEPTED STANDARDS OF ENGINEERING/MECHANICAL MAINTENANCE AND APPLY THEM THROUGHOUT THE MACHINE.

**THE FAILURE TO APPLY GENERALLY ACCEPTED
STANDARDS OF MAINTENANCE, OR THE PERFORMANCE
OF INAPPROPRIATE MAINTENANCE, MAY INVALIDATE
WARRANTY IN WHOLE OR IN PART.**

**PLEASE REFER TO YOUR AUTHORISED
TIMBERWOLF SERVICE AGENT FOR
SERVICE AND MAINTENANCE.**





SERVICE SCHEDULE

WARNING

Always immobilise the machine by stopping the engine, removing the ignition key and disconnecting the battery before undertaking any maintenance work.



SERVICE SCHEDULE	Daily Check	50 Hours	100 Hours	500 Hours	1 Year
Check water	✓				
Check engine oil - top up if necessary (10W-30).	✓				
Check for engine oil / hydraulic oil leaks.	✓				
Check fuel level.	✓				
Check feed funnel, feed roller cover, access covers, engine covers and discharge unit are securely fitted.	✓				
Check blades.	✓				
Check radiator is clear.	✓				
Check air intake is clear.	✓				
Clean air filter element.	DEPENDING ON WORKING ENVIRONMENT				
Lubricate variable track base slides (VTR only).	WEEKLY, DEPENDING ON WORKING ENVIRONMENT				
Check for tightness all nuts, bolts and fastenings making sure nothing has worked loose.		✓			
Grease discharge flange.		✓			
Check tension of main drive belts (and tension if necessary).		✓			
Grease the roller box slides.		✓ OR AS REQUIRED - SEE PAGE 22			
Grease the roller spline and bearing.		✓ OR AS REQUIRED - SEE PAGE 21			
Check anvils for wear.		✓			
Check safety bar mechanism.			✓		
Check fuel pipes and clamp bands.			✓		
Check battery electrolyte level.			✓		
Check for loose electrical wiring.			✓		
Replace track drive unit oil.		(1ST TIME) ✓	THEN ✓	OR ✓	✓
Replace hydraulic oil filter - every year or 100 hours after service or repair work to the hydraulic system.			✓	OR	✓
Replace hydraulic oil.			✓	OR	✓
Replace fuel pipes and clamp bands.	} REFER TO YOUR ENGINE SUPPLIERS MANUAL				
Check coolant.					
Change engine oil.					
Replace engine oil filter cartridge.					
Check valve clearance.					
Replace anvils when worn.	RETURN TO DEALER FOR ANVIL CHANGE				
Grease tandem pump spline drive.					✓

NOTE: Your Timberwolf woodchipper is covered by a full 12 months parts and labour warranty. Subject to correct maintenance and proper machine usage, the bearings are guaranteed for 12 months regardless of hours worked by the machine. In conditions of 'heavy usage' - i.e. in excess of 500 hours per year - it is recommended that the bearings are changed annually to ensure that the machine retains optimum working performance.



SAFE MAINTENANCE

ALWAYS IMMOBILISE THE ENGINE BEFORE UNDERTAKING ANY MAINTENANCE WORK ON THE CHIPPER BY REMOVING THE KEY AND DISCONNECTING THE BATTERY.

- HANDLE blades with extreme caution to avoid injury. Gloves should always be worn when handling the cutter blades.
- THE drive belts should be connected while changing blades, as this will restrict sudden movement of the rotor.
- THE major components of this machine are heavy. Lifting equipment must be used for disassembly.
- CLEAN machines are safer and easier to service.
- AVOID contact with hydraulic oil.

ENGINE SERVICING

All engine servicing must be performed in accordance with the Engine Manufacturer's Handbook provided with the machine. **FAILURE TO ADHERE TO THIS MAY INVALIDATE WARRANTY AND/OR SHORTEN ENGINE LIFE.**

SPARES

Only fit genuine Timberwolf replacement blades, screws and chipper spares. Failure to do so will result in the invalidation of the warranty and may result in damage to the chipper, personal injury or even loss of life.

SAFE LIFTING & SECURING DOWN OF THE CHIPPER

The lifting eye is designed to lift the machine's weight only. Do not use hoist hook directly on the lifting eye, use a correctly rated safety shackle. Inspect the lifting eye prior to each use - **DO NOT USE LIFTING EYE IF DAMAGED.**

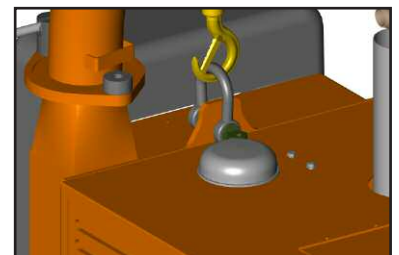

The method of securing the chipper can vary depending on the type of carrier and position of tie down points available on the carrier. Timberwolf recommend where possible to secure machine to carrier using correctly rated ratchet straps over the full length of both rubber tracks.

Securing a Timberwolf chipper ready for transport must be carried out by competent qualified personnel. Failure to observe this procedure could result in chassis and/or undercarriage damage.

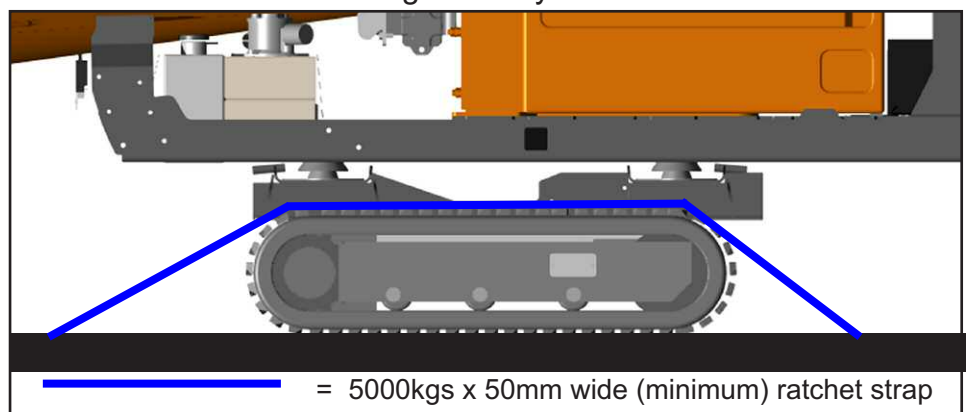

BATTERY REMOVAL AND MAINTENANCE

WARNING

Refer to the battery safety section on pages 17-18.



1. Remove the seven M6 bolts securing the tracking controls front guard.
2. Remove the two M10 bolts securing the battery clamp.
3. Remove the negative battery lead.
4. Remove the positive battery lead.
5. Refitting is the reverse of removal. Apply a smear of vaseline to the terminals to prevent corrosion.



COPPER EASE SAFETY INFORMATION

Product name: Copper Ease.

Copper Ease contains no hazardous ingredients at or above regulatory disclosure limits, however, safety precautions should be taken when handling (use of oil-resistant gloves and safety glasses are recommended - respiratory protection is not required). Avoid direct contact with the substance and store in a cool, well ventilated area avoiding sources of ignition, strong oxidising agents and strong acids. Dispose of as normal industrial waste (be aware of the possible existence of regional or national regulations regarding disposal), do not discharge into drains or rivers.

In case of fire: in combustion the product emits toxic fumes, extinguish with alcohol or polymer foam, carbon dioxide or dry chemical powder. Wear self-contained breathing apparatus and protective clothing to prevent contact with skin and eyes.

FIRST AID

Skin contact: there may be mild irritation at the site of contact, wash immediately with plenty of soap and water.

Eye contact: there may be irritation and redness, bathe the eye with running water for 15 minutes.

Ingestion: there may be irritation of the throat, do not induce vomiting, wash out mouth with water.

A safety data sheet for this product can be obtained by writing to the manufacturer at the following address: Comma Oil and Chemicals Ltd., Deering Way, Gravesend, Kent DA12 2QX. Tel: 01474 564311, Fax: 01474 333000.

BATTERY SAFETY INFORMATION

WARNING NOTES AND SAFETY REGULATIONS FOR FILLED LEAD-ACID BATTERIES



For safety reasons, wear eye protection when handling a battery.



Keep children away from acid and batteries.



Fires, sparks, naked flames and smoking are prohibited.
-Avoid causing sparks when dealing with cables and electrical equipment, and beware of electrostatic discharges.
-Avoid short circuits.



Explosion hazard:
-A highly explosive oxyhydrogen gas mixture is produced when batteries are charged.



Corrosive hazard:
-Battery acid is highly corrosive, therefore:
-Wear protective gloves and eye protection.
-Do not tilt the battery, acid may escape from the vent openings.



First aid:
-Rinse off acid splashed in the eyes immediately for several minutes with clear water! Then consult a doctor immediately.
-Neutralise acid splashes on the skin or clothes immediately with acid neutraliser (soda) or soap suds, and rinse with plenty of water.
-If acid is swallowed, consult a doctor immediately.

Warning notes: The battery case can become brittle, to avoid this:



-Do not store batteries in direct sunlight.
-Discharged batteries may freeze up, therefore store in an area free from frost.



Disposal:
-Dispose of old batteries at an authorised collection point.



-The notes listed under item 1 are to be followed for transport.
-Never dispose of old batteries in household waste.



BATTERY SAFETY INFORMATION...cont.

1. Storage and transport

- Batteries are filled with acid.
- Always store and transport batteries upright and prevent from tilting so that no acid can escape.
- Store in a cool and dry place.
- Do not remove the protective cap from the positive terminal.
- Run a FIFO (first in-first out) warehouse management system.

2. Initial operation

- The batteries are filled with acid at a density of 1.28g/ml during the manufacturing process and are ready for use.
- Recharge in case of insufficient starting power (cf. section 4).

3. Installation in the vehicle and removal from the vehicle

- Switch off the engine and all electrical equipment.
- When removing, disconnect the negative terminal first.
- Avoid short circuits caused by tools, for example.
- Remove any foreign body from the battery tray, and clamp battery tightly after installation.
- Clean the terminals and clamps, and lubricate slightly with battery grease.
- When installing, first connect the positive terminal, and check the terminal clamps for tight fit.
- After having fitted the battery in the vehicle, remove the protective cap from the positive terminal, and place it on the terminal of the replaced battery in order to prevent short circuits and possible sparks.
- Use parts from the replaced battery, such as the terminal covers, elbows, vent pipe connection and terminal holders (where applicable); use available or supplied filler caps.
- Leave at least one vent open, otherwise there is a danger of explosion. This also applies when old batteries are returned.

4. Charging

- Remove the battery from the vehicle; disconnect the lead of the negative terminal first.
- Ensure good ventilation.
- Use suitable direct current chargers only.
- Connect the positive terminal of the battery to

the positive output of the charger. Connect the negative terminal accordingly.

- Switch on the charger only after the battery has been connected, and switch off the charger first after charging has been completed.
- Charging current-recommendation: 1/10 ampere of the battery capacity Ah.
- Use a charger with a constant charging voltage of 14.4V for re-charging.
- If the acid temperature rises above 55° Celsius, stop charging.
- The battery is fully charged when the charging voltage has stopped rising for two hours.

5. Maintenance

- Keep the battery clean and dry.
- Use a moist anti-static cloth only to wipe the battery, otherwise there is a danger of explosion.
- Do not open the battery.
- Recharge in case of insufficient starting power (cf. section 4).

6. Jump Starting

- Use the standardised jumper cable in compliance with DIN 72553 only, and follow the operating instructions.
- Use batteries of the same nominal voltage only.
- Switch off the engines of both vehicles.
- First connect the two positive terminals (1) and (2), then connect the negative terminal of the charged battery (3) to a metal part (4) of the vehicle requiring assistance away from the battery.
- Start the engine of the vehicle providing assistance, then start the engine of the vehicle requiring assistance for a maximum of 15 seconds.
- Disconnect the cables in reverse sequence (4-3-2-1).

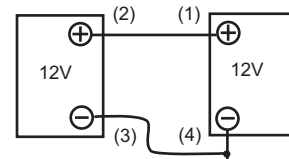

7. Taking the battery out of service

- Charge the battery; store in a cool place or in the vehicle with the negative terminal disconnected.
- Check the battery state of charge at regular intervals, and correct by recharging when necessary (cf. section 4).



CHANGE HYDRAULIC OIL AND FILTER

WARNING

Use plastic gloves to keep oil off skin and dispose of the used oil and filter in an ecologically sound way. The oil and filter should be changed once a year or at any time it becomes contaminated. Before starting check that the chipper is standing level and brush away loose chips.

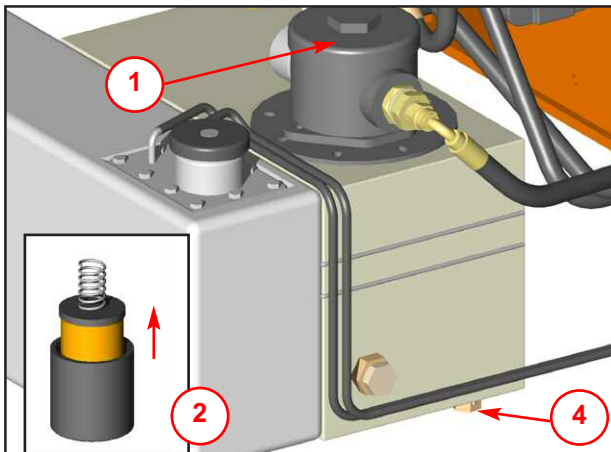

NOTE: This is a non-adjustable air breather filter.

1. Remove the black screw cap from the top of the filter housing.
2. Partially remove filter element from inner cup. Leave filter to drain for 15 minutes.
3. Remove filter element from cup when clear of hydraulic oil.
4. Remove drain plug and drain oil into a suitable container.
5. Replace drain plug.
6. Refill with VG 32 hydraulic oil until the level is between the min and max lines on the tank (about 15 litres).
7. Refit the filter cup, install a new filter element and refit the black screw cap, to the filter housing, ensuring o-ring remains in place.

CHECK FITTINGS

The Timberwolf TW 150VTR/FTR is subject to large vibrations during the normal course of operation. Consequently there is always a possibility that nuts and bolts will work themselves loose. It is important that periodic checks are made to ensure the security of all fasteners. Fasteners should be tightened using a torque wrench to the required torque (see below). **Uncalibrated torque wrenches can be inaccurate by as much as 25%. It is therefore essential that a calibrated torque wrench is used to achieve the tightening torques listed below.**

	Size	Pitch	Head	Torque lbft	Torque Nm
Blade Bolts	M10	Standard	T50 Torx	45	61
Hyd Motor Retaining Bolts	M10	Standard	17mm Hex	34	46
Funnel Retaining Nuts	M12	Standard	17mm Hex	38	51
General	M8	Standard	13 mm Hex	17	23
General	M10	Standard	17 mm Hex	34	46
General	M12	Standard	19 mm Hex	60	80
Drain Bung in Fuel Tank	3/8" BSP	-	22 mm Hex	25	33.8

CHECK HOSES

All the hydraulic hoses should be regularly inspected for chafing and leaks. The hydraulic system is pressurized to over 150 Bar (2175 PSI) and thus the equipment containing it must be kept in good condition.

Identify the hoses that run to the top motor. These have the highest chance of damage as they are constantly moving. If any hydraulic components are changed new seals should be installed during reassembly. Fittings should then be retightened.



CHANGE BLADES

WARNING

Wear riggers gloves for the blade changing operation.

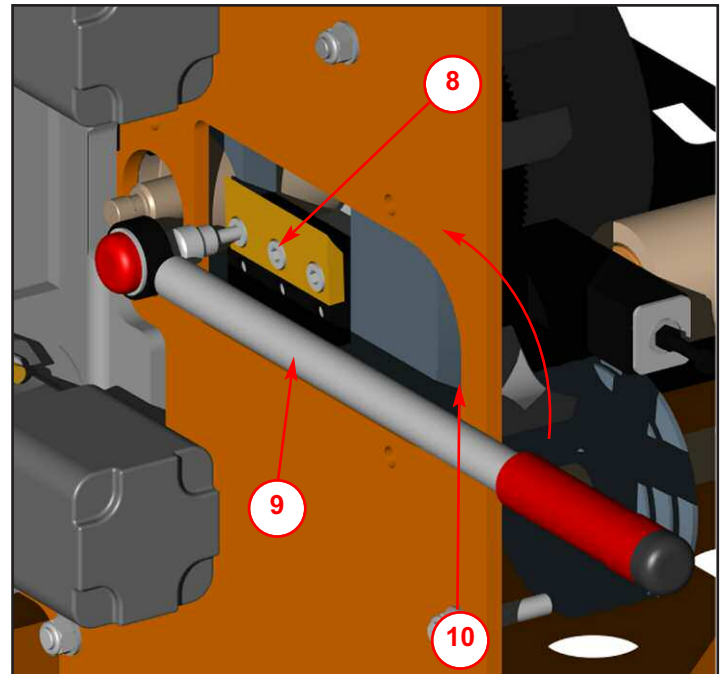
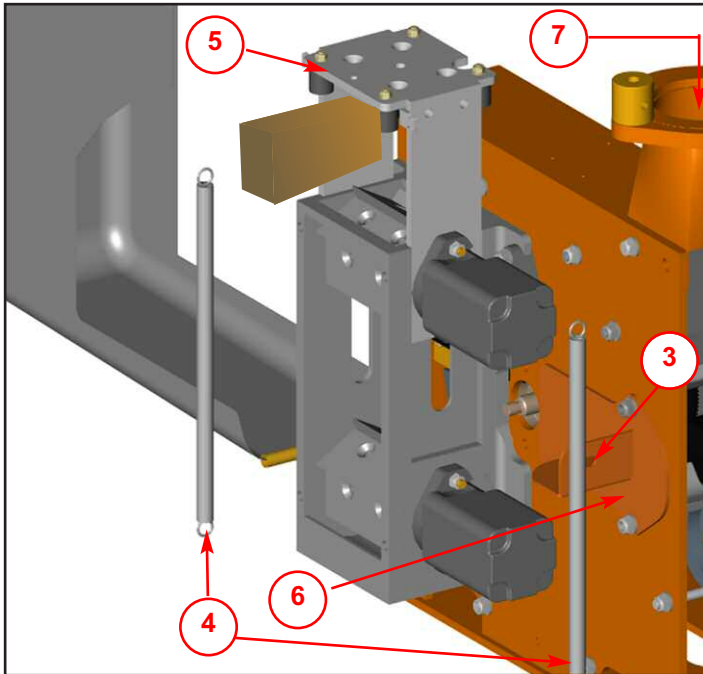

1. Turn the chipper off and remove the ignition keys.
2. Remove battery leads.
3. Remove bolt and washer retaining roller box guard and lift guard.
4. Remove the two springs on the roller box slide.
5. **NOTE: Rollerbox slide weighs in excess of 20kg.** Lift the roller box slide and wedge a suitably sized piece of wood to hold in place.
6. Remove blade access cover.
7. Remove discharge tube. Turn the rotor by hand by grasping fan section on rear of rotor disc until blade is visible through aperture.
8. Use a small screwdriver to remove sap and debris from Torx socket in screw - be particularly careful to ensure every last piece has been removed.
9. Undo blade screws using Torx socket drive provided. Rotor will turn until Torx socket has located on machine.
10. **Before fitting replacement blades carefully clean blade recess in rotor so that no debris is trapped between blade and rotor.**
11. When fitting blades replace any damaged screws with new and coat each screw with copperslip over the whole of the thread.
12. **Retighten each screw to 60Nm (45lbs ft).**
NOTE: This torque setting is vitally important to ensure your bolts come out at a later date and Timberwolf recommend you purchase a torque wrench for this and other jobs on the chipper.
13. Grease all surfaces of the roller box sliding mechanism (see diagram on page 20).
14. Replace blade access cover.
15. **NOTE: Rollerbox slide weighs in excess of 20kg.** Remove wedge, lower roller box slide and replace springs.
16. Close roller box guard making sure that it is located over the retaining bracket, and ensure bolt and washer (as note 3) are tightened.
17. Refit battery leads.

WARNING



Always sharpen blades on a regular basis. Failure to do so will cause the machine to under perform and will overload engine and bearings causing machine breakdown. Blades must not be sharpened beyond the wear mark (see diagram). Failure to comply with this could result in machine damage, injury or loss of life.





TENSION DRIVE BELTS

NOTE: There will normally be a rapid drop in tension during run-in period for new belts. When new belts are fitted, check the tension every 2 - 3 hours and adjust until the tension remains constant.

Belt failures due to lack of correct tensioning will not be covered under your Timberwolf warranty.

TENSION DRIVE BELTS

1. Remove side panel.
2. Loosen bolt in centre of tensioner pulley with a 19 mm spanner so that pulley is able to slide with minimal wobble.
3. Turn nut in end of tensioner pulley slider until correct belt tension is achieved. For instructions on checking belt tension & correct belt tension values, please refer to the Timberwolf V-Belt Tensioning Data Table (pg. 56).
5. Re-tighten bolt in centre of tensioner pulley.
6. Run machine and test, recheck belt tension.
7. **NOTE:** Slack drive belts will cause poor performance and excess belt and pulley wear.

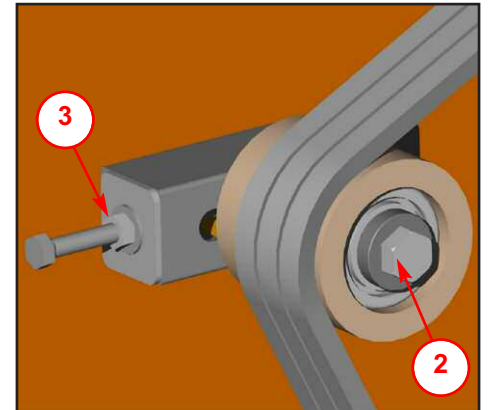

TENSION HYDRAULIC PUMP BELT

1. Loosen the three outermost M8 nuts and bolts.
2. Pivot pump assembly up or down to achieve the correct belt tension. For instructions on checking belt tension & correct belt tension values, please refer to the Timberwolf V-Belt Tensioning Data Table (pg. 56).
3. Hold assembly at this position while tightening the three M8 nuts and bolts.

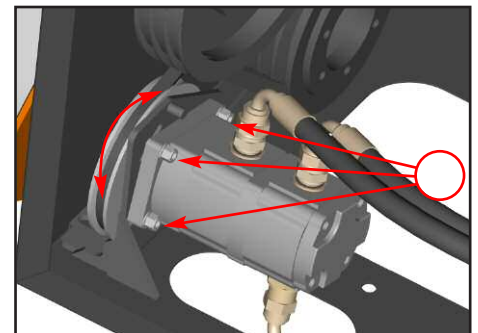

GREASE THE DISCHARGE FLANGE

1. Remove the discharge tube.
2. Apply multipurpose grease to surface shown.
3. Refit discharge tube.

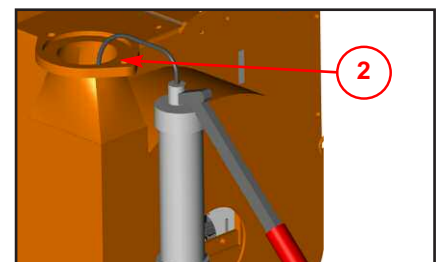

GREASE THE ROLLER SPLINE AND BEARING

NOTE: This should be done regularly. In dirty and dusty conditions or during periods of hard work it should be weekly. If the bearings and splines are allowed to run dry premature wear will occur resulting in a breakdown and the need for replacement parts. This failure is not warranty. Early signs of insufficient grease includes squeaking or knocking rollers.

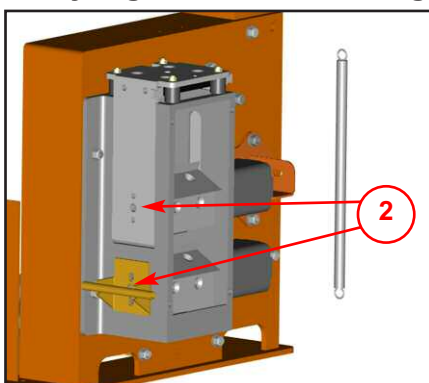

1. Remove bolt and washer retaining roller box guard and lift guard (see diagram on page 18).
2. Locate two grease nipples; one in the centre of each roller shaft.
3. Use a pump action grease gun to apply a generous amount of grease to each roller drive. **DO NOT USE GRAPHITE BASED GREASE.** After applying grease, to penetrate all the bearing surfaces thoroughly, start the machine and operate the rollers for 20 seconds. Switch off the machine. Repeat this greasing/running procedure a further 3 times.
4. Close roller box guard making sure that it is located over the retaining bracket, and ensure bolt and washer are tightened.



GREASE THE ROLLER BOX SLIDES

NOTE: This should be done regularly. In dirty or dusty conditions or during periods of hard work it should be done weekly. If the slides become dry the top roller will tend to hang up and the pulling-in power of the rollers will be much reduced. Excessive wear will ensue.

1. Turn the chipper off and remove the ignition keys.
2. Ensure machine has come to a complete stop - remove battery leads.
3. Remove the bolt and washer retaining roller box guard and lift guard.
4. Remove the two springs on the roller box slide.
5. **NOTE: Rollerbox slide weighs in excess of 20kg.** Lift the top roller and wedge a suitably sized piece of wood to hold in place.
6. Apply thin grease with a brush to each slide on roller box and on inner cheeks of slider. **DO NOT USE GRAPHITE BASED GREASE.**
7. **NOTE: Rollerbox slide weighs in excess of 20kg.** Remove wedge, lower roller box slide and replace springs.
8. Close roller box guard making sure that it is located over the retaining bracket, and ensure bolt and washer (as note 3) are tightened.
9. Refit battery leads.

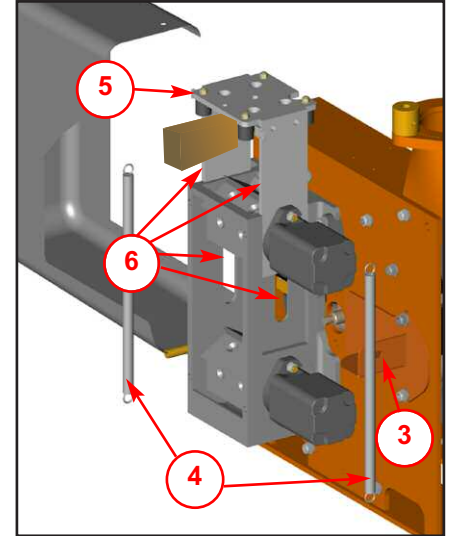

GREASING ROTOR BEARINGS

Both front and rear bearings are sealed and do not need greasing.

TRACK BASE MAINTENANCE

SAFE MAINTENANCE

- Solidly support the under carriage if it needs to be lifted up for maintenance (see Chassis Jacking Point section on page 12).
- Hydraulic systems may get very hot after working.
- Keep all components in good condition as they are exposed to high pressures.
- Immediately repair damage and replace worn or broken items.
- Keep the tracks clean, removing excess oil, grease and dirt.
- Check for oil leaks and damaged hoses.
- Only use recommended lubricants. Do not mix different brands.
- Keep track stretcher grease nipples clean.

Immediately repair damage and replace worn or broken items.

Maintenance intervals are only guidelines. The amount of times maintenance is conducted should be increased beyond recommended guidelines if severe conditions are encountered.

LUBRICATE VARIABLE TRACK BASE SLIDES (VTR)

The variable track base slides must be lubricated weekly or more often depending working conditions to prevent jamming.

1. Extend tracks fully.
2. Using a brush, generously coat all surfaces of the four slider bars with general purpose grease. **DO NOT USE GRAPHITE BASED GREASE.**
3. Retract the tracks fully.
4. Cycle tracks in and out two more times.

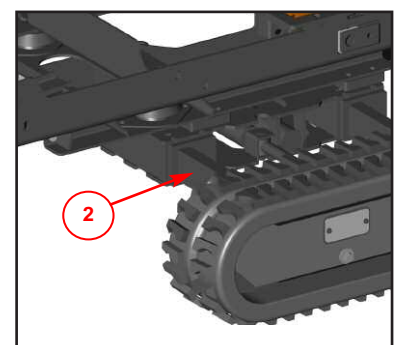



REPLACE OIL IN THE TRACK DRIVE UNIT

To fill with oil, track the machine until the gearbox casing is level with a plug positioned at 12 o'clock as shown. Unscrew the two plugs and fill from the upper hole until oil reaches the level of the lower hole.

NOTE - Ensure the correct grade of oil is used: Gear Oil EP80W-90 GL5

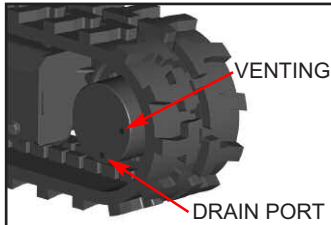
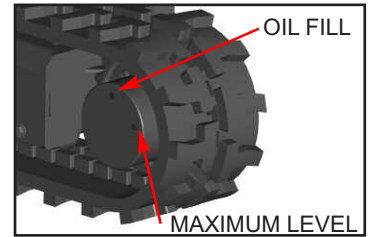

DRAINING THE OIL IN THE TRACK DRIVE UNIT

To drain the oil, track the machine until a plug is at 6 o'clock as shown. Unscrew both plugs and allow oil to discharge into a suitable container. Dispose of waste oil in a safe and approved way.

REDUCTION UNIT OIL TYPES

We recommend, for track drive gearboxes, using gear oils with E>P. additives and viscosity to SAE 80W/90 or ISO VG 150. Continuous duty temperature must not exceed 90°C.

CHECKING THE RUBBER TRACKS

The structure of the rubber track is shown in this diagram. The steel cables (1) and metal core (2) are embedded in the rubber.

There are many ways in which rubber tracks may be damaged. Some of these are terminal for the tracks, others are only cosmetic.

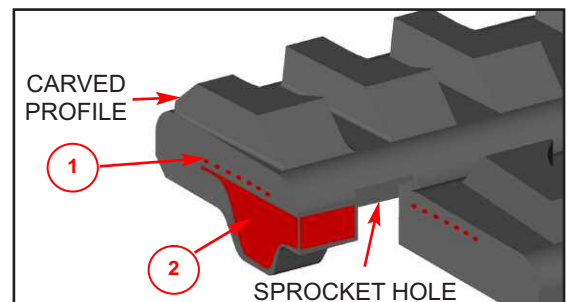

BREAKAGES OF STEEL CABLES AND METAL CORES.

- Excess track tension can cause steel cables to break. Excess tension may be caused by;
- Stones or foreign matter accumulating between the track and the undercarriage frame.
- The track slipping off its guide system.
- Extreme friction such as rapid changes in direction.
- Improper contact between track and sprocket.
- Operation on sandy terrain.

FATIGUE CRACKS AND ABRASION.

Cracks at the base of tile carved profiles are caused by rubber fatigue due to bending.

Cracks and bends on the edge of the rubber are caused by manoeuvring the track on concrete edges and curbs.

Cracks and abrasions in the rubber on the guide roller paths are caused by compression fatigue of the rubber due to the weight of the wheel combined with operation on sandy terrain or repeated sudden changes in direction.

Abrasion of the carved profile may be caused, in particular, by rotation on concrete or gravel surfaces or hard surfaces.

Cracks on the outside surface of the track are often due to contact with gravel, sharp stones and sharp materials such as sheet metal, nails and glass.

Cracks on the inside surface of the circumference and on the edge of the rubber are caused by contact between track and the undercarriage structure or with sharp concrete edges.

These methods of damage are progressive. The track can continue to be used until wear exposes the metal cores. If this exposure extends for more than half of the circumference of the track then it is time to replace the track, even though it can still be used.



CHECKING TRACK TENSION

1. Stop your machine on a flat and solid surface.
2. Lift it in safe conditions and put stable supports under the undercarriage frame to properly support it.
3. Measure distance A at the central roller of the undercarriage from the bottom of the roller to the rigid inside surface of the rubber track. Track tension is normal if dimension A is between 70 and 75 mm.
4. Adjust tension as described in the following paragraph if track tension does not comply with these dimensions (loose or too tight).

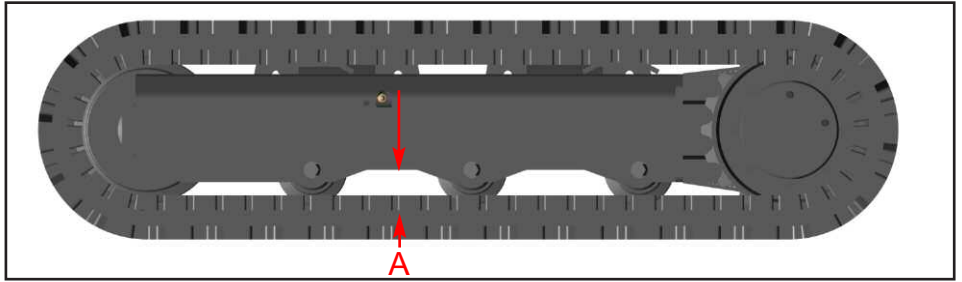

TRACK LOOSENING/TIGHTENING PROCEDURES

Track tension is maintained by grease in the adjuster unit. Adding more grease will increase track tension, removing grease will decrease it.

The grease contained in the hydraulic track tensioner ram is pressurized. Never release grease nipple (No. 1, Fig. 1) for more than necessary to slowly release grease to a maximum of five turns. If the valve is loosened too much you risk expelling grease under pressure and possible injury to the machine operator. Remove gravel or mud when they are jammed between the sprocket and the track link before loosening the track.

1. Locate access hole in side frame (fig. 1) to access the adjustment system.
2. To loosen the track turn the grease nipple counter-clockwise slowly, the grease should begin to be expelled after approximately two turns.
3. If grease does not start to drain out then slowly rotate the track forward and reverse to free adjuster mechanism - grease may then be expelled under pressure as track tension is relieved.

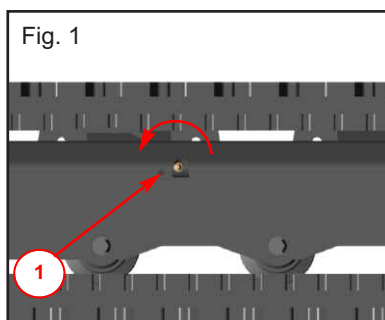

4. When you have obtained correct track tension then turn valve clockwise and tighten it. Clean all traces of extruded grease.
5. To stretch the track connect a grease gun to grease nipple and add grease until track tension falls within specified values.

WARNING

It is not normal for the track to remain too tight after turning the grease nipple counter-clockwise or for it to remain loose after introducing grease into the grease nipple. Never try to remove the tracks or disassemble the track-stretching cylinder since pressure of the grease inside the track is dangerous.





REMOVING THE RUBBER TRACKS

Remove gravel or mud when they are jammed between the sprocket and the track link before loosening the track.

1. Stop your machine on a solid and level surface. Lift it up and support it in safe conditions.
2. Locate access holes in side frame to access to the adjustment system (Fig. 1, page 24).
3. To loosen a track turn the grease nipple counter-clockwise slowly then the grease should begin to be expelled after approximately 2 turns.
4. If grease does not start to drain out then slowly rotate the track forward and reverse to free adjuster mechanism.
5. Insert three steel tubes inside the track in the space between the rollers.
6. Rotate the driving gear in reverse so that the steel tubes proceed with the track and engage in the track-stretching wheel.
7. Exercise force sideways to slide the track and lift it off the track-stretching wheel.

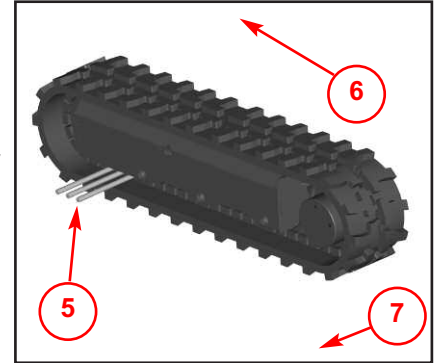

WARNING

The grease contained in the hydraulic tensioner is under pressure. Never loosen the grease nipple for more than 5 turns. If the grease nipple is loosened too much then pressurized grease may exit and cause injury to the machine operator.



INSTALLING THE RUBBER TRACKS

WARNING

Make sure that you are always in safe conditions with the machine lifted to perform the operation for track installing.

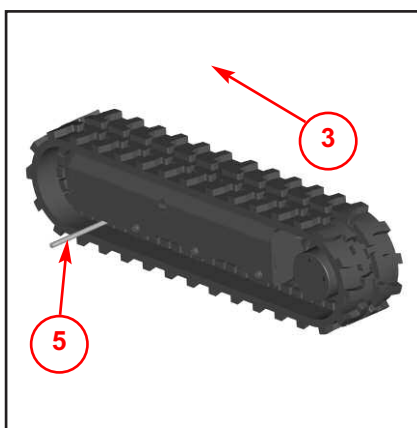

1. Check that the grease contained in the hydraulic cylinder has been removed.
2. Mesh the track links in the sprocket and place the other end of the track on the track-stretching wheel.
3. Rotate the driving gear in reverse and pull the track soles inside the frame.
4. Position the track using a steel tube and turn the driving gear again.
5. Make sure track links mesh correctly in the sprocket and in the track stretching wheel.
6. Adjust track tension (see track loosening procedures on page 24).
7. Set the tracked undercarriage on the ground.

CHECKING SPROCKET WEAR

Measuring wear on sprocket and driving gear teeth is one of the most difficult measurements to be done. You must always consider the point where wear is greatest.

There should always be enough tooth left on the sprocket to engage fully with the rubber track. When the sprocket meshing distance is reduced significantly the sprocket should be changed.



ENVIRONMENTAL MANUFACTURING LLP 12 MONTH CHIPPER WARRANTY

WARRANTY PERIOD

The warranty period for the woodchipper commences on the date of sale to the first end user and continues for a period of 12 months. This guarantee is to the first end user only and is not transferable except when an authorised Timberwolf Dealer has a woodchipper registered with Environmental Manufacturing LLP as a hire chipper or long term demonstrator – in these situations they are duly authorised to transfer any remaining warranty period to their first end user. Any warranty offered by the Timberwolf Dealer beyond the original 12 month period will be wholly covered by said Dealer.

LIABILITY

Our obligation under this warranty is limited to repair at Environmental Manufacturing LLP premises or at our option an Environmental Manufacturing LLP approved Timberwolf dealer. No liability will be accepted for special, indirect, incidental, or consequential loss or damages of any kind.

WARRANTY STATEMENT

Environmental Manufacturing LLP warrants to the first end user that;

- Your woodchipper shall be designed, built and equipped, at the point of sale, to meet all current applicable regulations.
- Your chipper shall be free from manufacturing defects both in materials and workmanship in normal service for the period mentioned above.

Warranty will not apply to a failure where normal use has exhausted the life of a component.

Engine units are covered independently by their respective manufacturer warranties.

OWNERS WARRANTY RESPONSIBILITIES

As the owner of an Environmental Manufacturing LLP woodchipper you are responsible for the following;

- Operation of the woodchipper in accordance with the Environmental Manufacturing LLP instruction manual.
- Performance of the required maintenance listed in your Environmental Manufacturing LLP instruction manual.
- In the event of a failure the Environmental Manufacturing LLP authorised Timberwolf dealer is to be notified within 10 days of failure and the equipment is to be made available for unmolested inspection by the dealer technician.

WARRANTY RESTRICTIONS

The Environmental Manufacturing LLP warranty is restricted to the first end user only and is not transferable except when an authorised Timberwolf Dealer has a woodchipper registered with Environmental Manufacturing LLP as a hire chipper or long term demonstrator – in these situations they are duly authorised to transfer any remaining warranty period to their first end user.

The Environmental Manufacturing LLP warranty may be invalidated if any of the following apply;

- The failed parts or assembly is interfered with in any way.
- Normal maintenance has not been performed.
- Incorrect reassembly of components.
- The machine has undergone modifications not approved in writing by Environmental Manufacturing LLP.
- In the case of tractor driven equipment, use has been on an unapproved tractor.
- Conditions of use can be deemed abnormal.
- The machine has been used to perform tasks contrary to those stated in the Environmental Manufacturing LLP instruction manual.

WARRANTY SERVICE

To obtain warranty service please contact your nearest Environmental Manufacturing LLP approved Timberwolf dealer. To obtain details of the nearest facility please contact Environmental Manufacturing LLP at the address on the front of this manual.

These warranty terms are in addition to and not in substitution for and do not affect any right and remedies which an owner might have under statute or at common law against the seller of the goods under the contract by which the owner acquired the goods.



CERTIFICATE OF CONFORMITY

Environmental Manufacturing LLP

Entec House,
 Tomo Industrial Estate,
 Stowmarket,
 Suffolk IP14 5AY
 Tel: 01449 765800 Fax: 01449 765801

E C Declaration of Conformity



Environmental Manufacturing LLP as the designer and manufacturer, certifies that the machine stipulated below complies with all the relevant provisions of the:

Machinery Directive; 2006/42/EC (& other relevant directives)

and the National Laws and Regulations adopting these directives.

Designer/Manufacturer : Environmental Manufacturing LLP

Description of Machinery : Self-powered portable machine intended to chip up tree waste prior to disposal.

Model : TW 150 VTR/FTR

Serial No. : Serial Manufacture

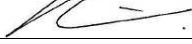

BSI Transposed Harmonised Standards applied: (including parts/clauses of):
BS EN 12100-1: 2010 Safety of Machinery- Basic concepts, BS EN 13857-1: 2008 Safety of Machinery-Safety distances to danger zones, BS EN 60204-1: 2006 +A1 2009 Safe electrical practices, BS EN 13732-1:2008 Safety of Machinery – Temperatures of touchable surfaces, BS EN 13849-1: 2008 – Safety of Machinery – Safety related parts of control systems, BS13850:2008 safety of Machinery Emergency stop BS EN 982: 1996 + A1 2005 – Safety of Machinery – Hydraulics, BS EN 1088: 1995 + A2 2008 – Safety of Machinery – Interlocking devices, BS EN 13525: 2005 + A2 2009 – Forestry Machinery – Wood chippers – Safety. BS EN 953:1997+A1:2009

“Responsible” Person empowered to sign:  Mr. Jeff Haines
 Position in Company: Technical Director

Date: 31 July 2014



IDENTIFICATION PLATE

	ENVIRONMENTAL MANUFACTURING LLP STOWMARKET, SUFFOLK IP14 5AY UK		
MODEL	<input type="text"/>		
SERIAL NO.	<input type="text"/>		
CARR. TYP/SN.	<input type="text"/>	GROSS WEIGHT	<input type="text"/>
NOM. POWER	<input type="text"/>	DATE	<input type="text"/>



Decal	Description	Decal	Description
<p>616</p>	Hot exhaust	<p>4099</p>	Danger. Rotating blades. Keep hands and feet out.
<p>617</p>	High velocity discharge - keep clear	<p>2800 2801</p>	Reverse feed Forward feed
<p>670</p>	Personal Protective Equipment required	<p>2802</p>	Push to stop, Pull to reset. (rollers)
<p>1661</p>	Read the instruction manual for greasing and maintenance information	<p>2854</p>	Do not ride on this machine at any time.
<p>1662</p>	The instruction manual with this machine contains important operating, maintenance and health and safety information. Failure to follow the information contained in the instruction manual may lead to death or serious injury.	<p>2949</p>	Lifting eye is designed to lift the machine's weight only. Do not use hoist hook directly on lifting eye. Use correctly rated safety shackle only through lifting eye. Lifting eye to be inspected every 6 months or before each use. Always visually inspect lifting eye prior to each use. Do not use lifting eye if damaged.
<p>1745</p> <p>17450</p>	Track Chip Select Chip mode when adjusting track width	<p>3022</p>	Clean under blades before refitting or turning. Failure to do so may result in blade(s) coming loose and damage being caused to the rotor housing.
<p>1747</p>	Chip	<p>18438</p>	When re-fitting this guard ensure that steel retaining bracket is on the inside. Damaged guards due to incorrect assembly will not be covered by your Timberwolf warranty.
<p>19517</p>	Warning Do not engage starter motor for more than 20 seconds. Allow one minute before attempting to start. Investigate reasons for failure to start. Excessive cranking will result in starter motor failure. This will not be covered under warranty.	<p>P691</p>	Do not pull here.
<p>1399</p> <p>3054</p>	Push to stop. Push OR pull to stop. (on low funnel only)	<p>3059</p>	Jacking point. See manual for instructions.



Decal	Description	Decal	Description		
	<p>P637</p> <p>Danger. Do not operate without this cover in place.</p>		<p>P653</p> <p>Danger. Rotating blades inside. Stop engine and remove key before removing discharge unit.</p>		
	<p>P652</p> <p>Caution. Do not put road sweepings in machine as grit will damage blades.</p>		<p>P654</p> <p>Caution. When transporting, discharge clamps may work loose. Check frequently.</p>		
	<p>P655</p> <p>Caution. Avoid standing directly in front of feed funnel to reduce exposure to noise, dust and risk from ejected particles.</p>		<p>P656</p> <p>Danger. Do not use this machine without the discharge unit fitted. Failure to comply may result in serious injury or damage.</p>		
	<p>18393</p> <p>New drive belts need re-tensioning. When new belts are fitted check tension every 2-3 hours & adjust until tension remains constant.</p>		<p>P650</p> <p>Danger. Autofeed system fitted. Rollers may turn without warning! When the engine is switched off the rollers will turn during the run down period.</p>		
	<p>19518</p> <p>When the emergency stop button is pressed it must be pulled out again and the ignition switch turned off to reset the machine before attempting to restart.</p>		<p>P1301</p> <p>Push to stop, Pull to reset. (engine)</p>		
3004	2998	1746	2950	18008	1363
		<p>TIMBERWOLF TIMBERWOLF TW 150VTR TW 150FTR</p>			
3015	4284	P*158	4275		

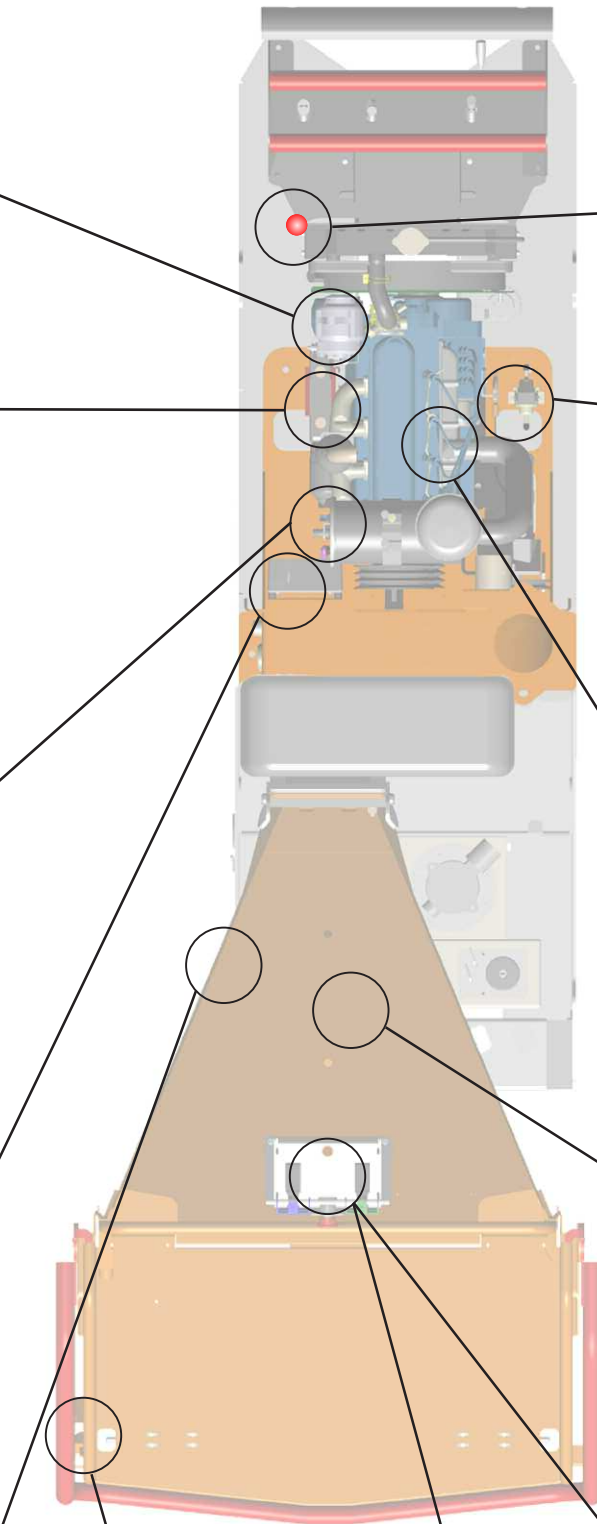
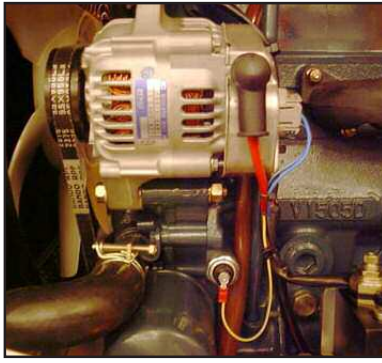

High funnel
versions only

Low funnel
versions only



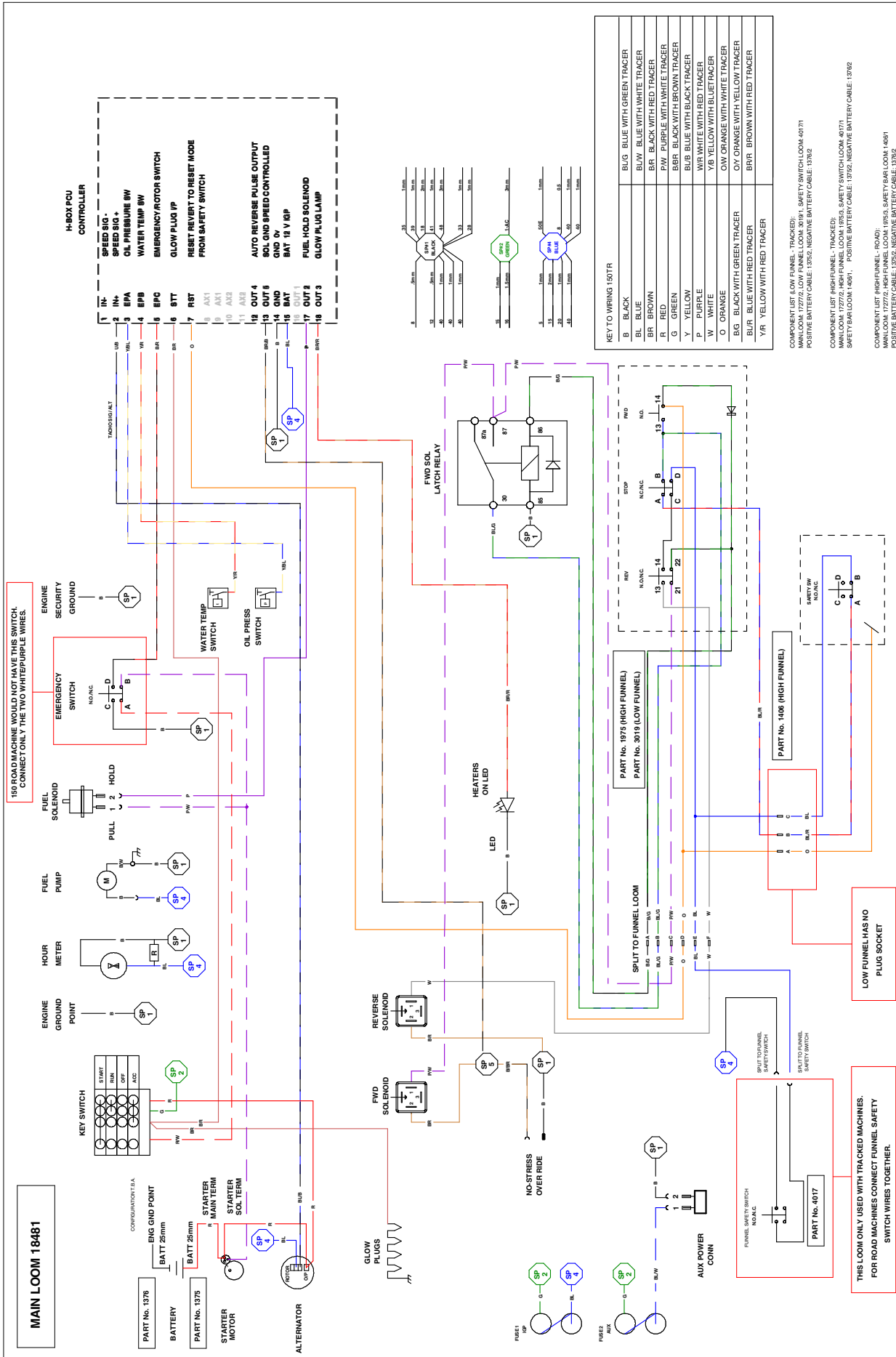



KIT NO: 18816

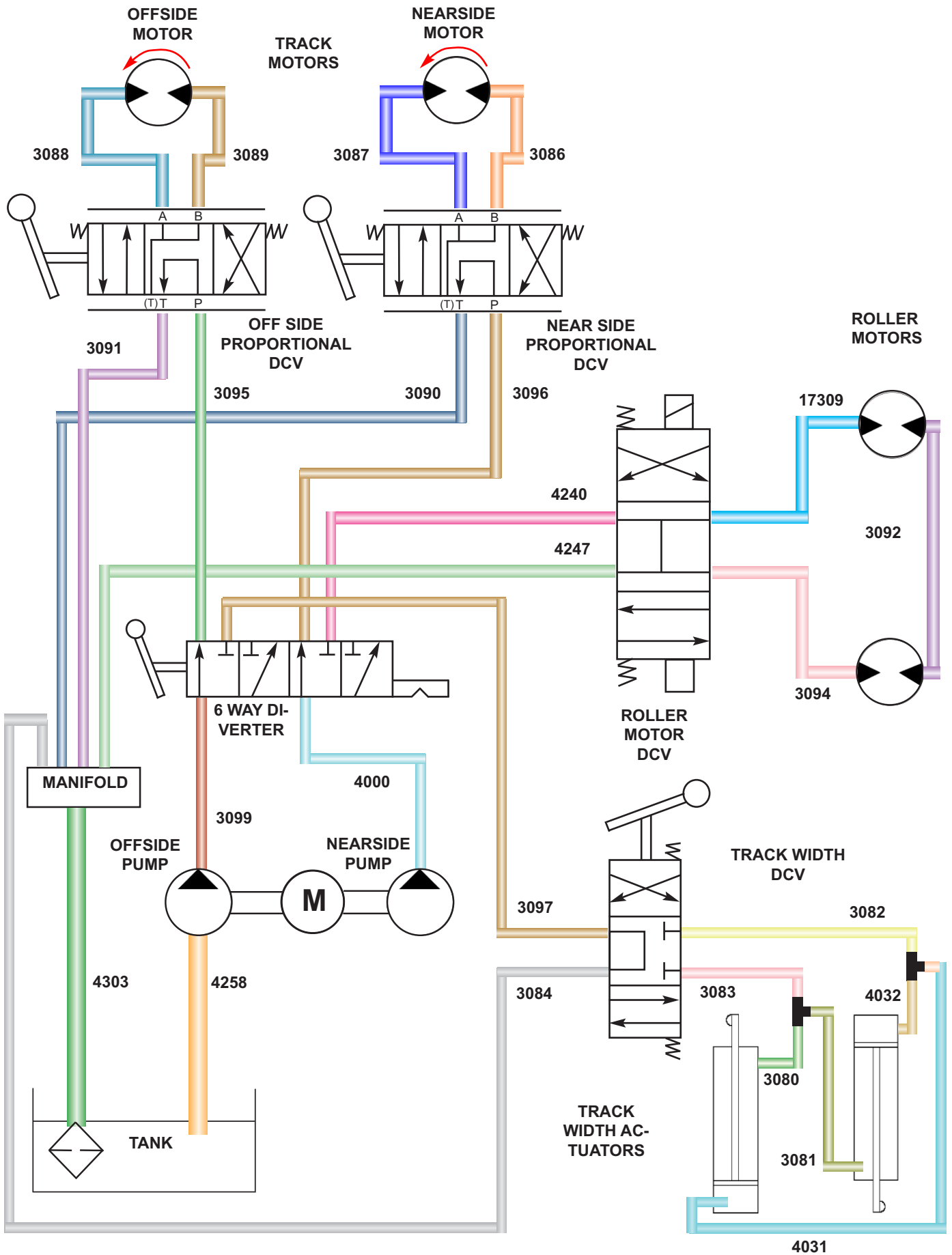



KIT NO: P*1182

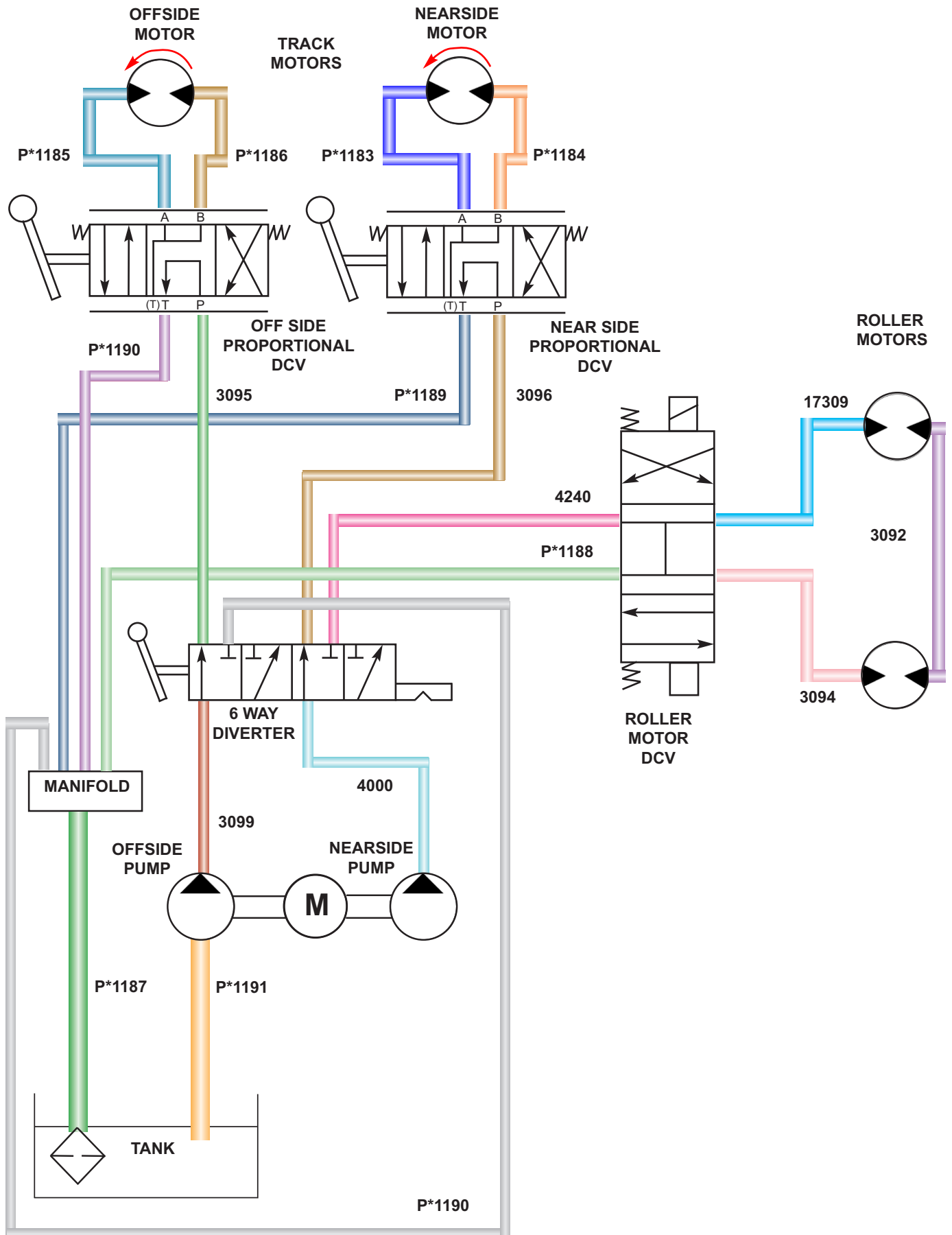



PARTS LISTS

The following illustrations are for parts identification only. The removal or fitting of these parts may cause a hazard and should only be carried out by trained personnel.

	<i>Page No.</i>
BELT TENSIONER	37
CHASSIS - VTR (1)	38
CHASSIS - VTR (2)	39
CHASSIS - FTR (1)	40
CONTROL BOX (UPPER SECTION)	41
CONTROL BOX (LOWER SECTION)	42
CONTROL TOWER	43
DECALS	See pages 29 - 30
DISCHARGE	44
DRIVE TRAIN	45
ELECTRICAL / CONTROL PANELS	46
ELECTRICAL LAYOUT	47
ENGINE	48
ENGINE BAY	49
FUEL TANK	50
FUNNEL (HIGH)	51
FUNNEL (LOW)	52
HYDRAULICS - VTR (1)	53
HYDRAULICS - VTR (2)	54
HYDRAULICS - VTR (3)	55
HYDRAULICS - FTR (1)	56
HYDRAULICS - FTR (1)	57
ROLLER BOX	58
ROTOR	59
ROTOR HOUSING	60
V-BELT TENSIONING TABLE	61

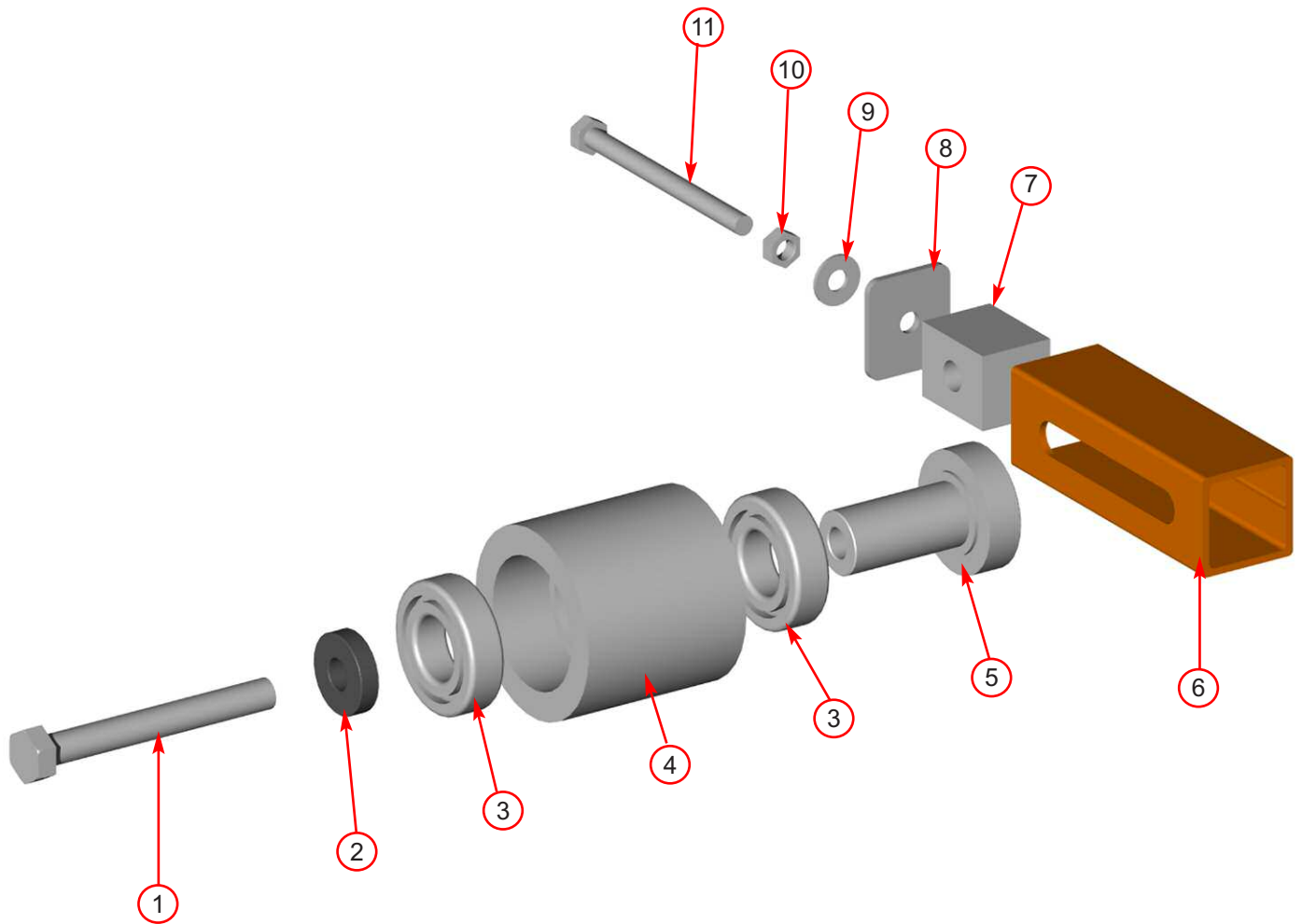

Item	Part No	Part Name	Q'ty
1	0313	M12/100 Bolt	1
2	0415	Heavy Washer	1
3	0491	Bearing 6205	2
4	0411M	Pulley	1
5	0472M	Pulley Boss	1
6	<i>N/A to purchase</i>	Slider	1
7	0469MS	Slider Block	1
8	1342PS	End Plate	1
9	<i>made in production</i>	Washer	1
10	0476	Plain M8 Nut	1
11	2988	M8/90 Bolt	1

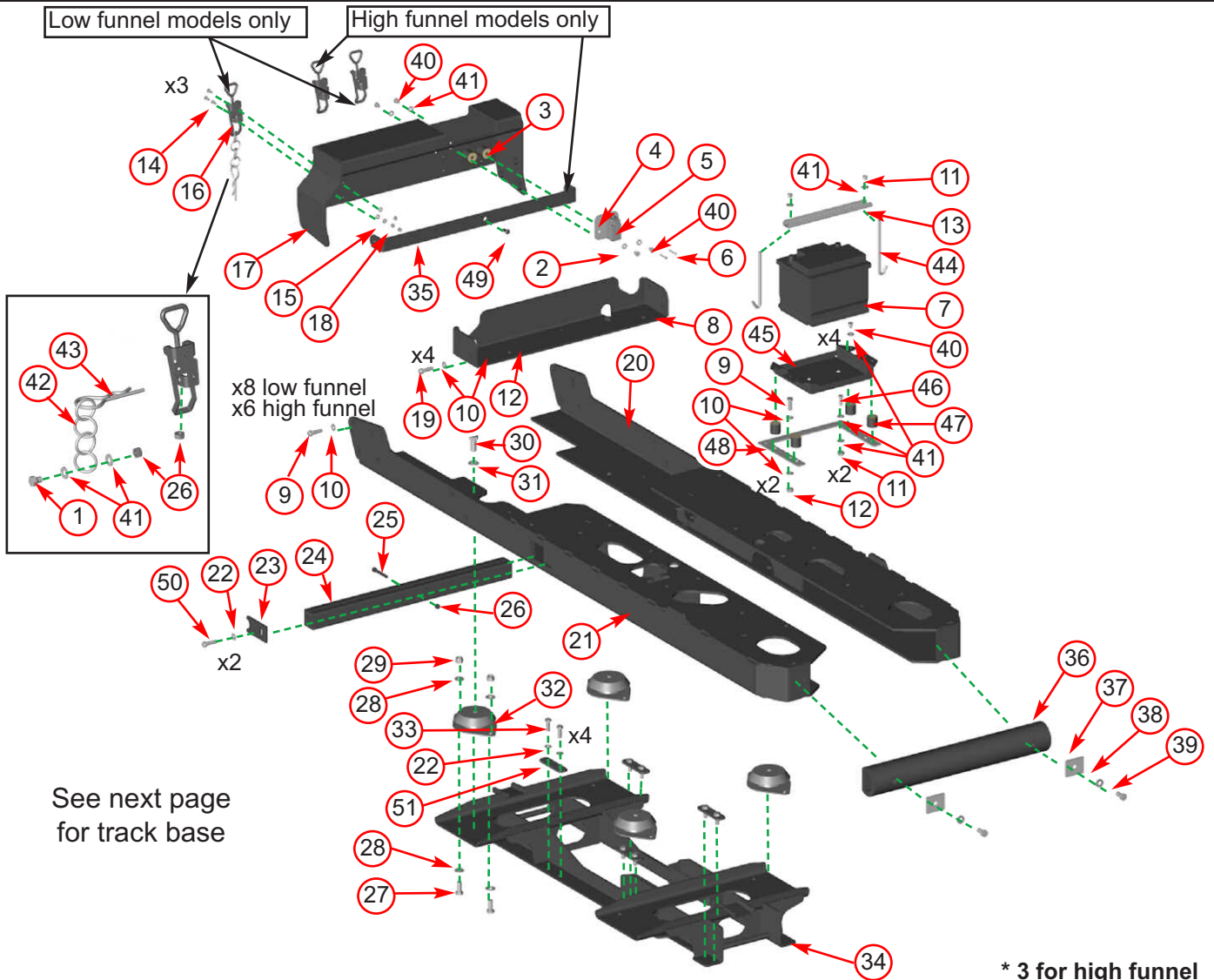

See next page
for track base

* 3 for high funnel

Item	Part No	Part Name	Q'ty
1	0346	M8/20 Bolt	2
2	0711	M8 A Washer	2
3	1868	M8 AV Mount	2
4	1691FS	Switch Back Plate	1
5	1692	Limit Switch	1
6	18168	M4/35 Pan Pozi	2
7	4210	Battery	1
8	3042FB	Chassis Bridge	1
9	0360	M10/25 Bolt	18
10	0701	M10 A Washer	20
11	0479	M8 P Nyloc Nut	4
12	0052	M10 T Nyloc Nut	4
13	18040FS	Battery Clamp	1
14	0256	M5/16 Csk Socket Screw	6*
15	0708	M5 C Washer	6*
16	4092	Draw Latch <i>High Funnel 1, Low Funnel 2</i>	
17	3010FB	Funnel Support	1
18	18102	M5 T Nyloc Nut	6*
19	1812	M10/35 Bolt	4
20	2990FB	Near Side Beam	1
21	2991FB	Off Side Beam	1
22	0839	M10 C Washer	10
23	4008B	Jacking Beam Cover	1
24	4007FB	Jacking Beam	1
25	0354	M8/60 Bolt	1
26	0481	M8 T Nyloc Nut	3

Item	Part No	Part Name	Q'ty
27	0321	M12/30 Bolt	8
28	0704	M12 C Washer	16
29	0644	M12 P Nyloc Nut	8
30	1628	M16/35 Bolt	4
31	1143	M16 A Washer	4
32	1796	M16 AV Mount	4
33	0382	M10/30 Bolt	8
34	1869FB	Track Mount Adapter Bracket	1
35	4106FB	Tank Stop Bar	1
36	2930	Rubber Buffer	1
37	4067S	D Rubber Fixing Plate	1
38	0702	M12 A Washer	2
39	0431	M12/40 Bolt	2
40	18037	M8/12 Bolt	6
41	0712	M8 C Washer	15
42	4105	Chain 40 x 16 x 3.8	2
43	4094	R Clip 5 mm x 85	2
44	18041	M8 x 170 Hook Bolt	2
45	18039FB	Battery Tray	1
46	0350	M8/25 Bolt	2
47	1644	AV Mount	4
48	18038FS	Battery Base Plate	1
49	0347	M8/20 Button Head	1
50	0382	M10/30 Bolt	2
51	P*163	Clamp Plates	4

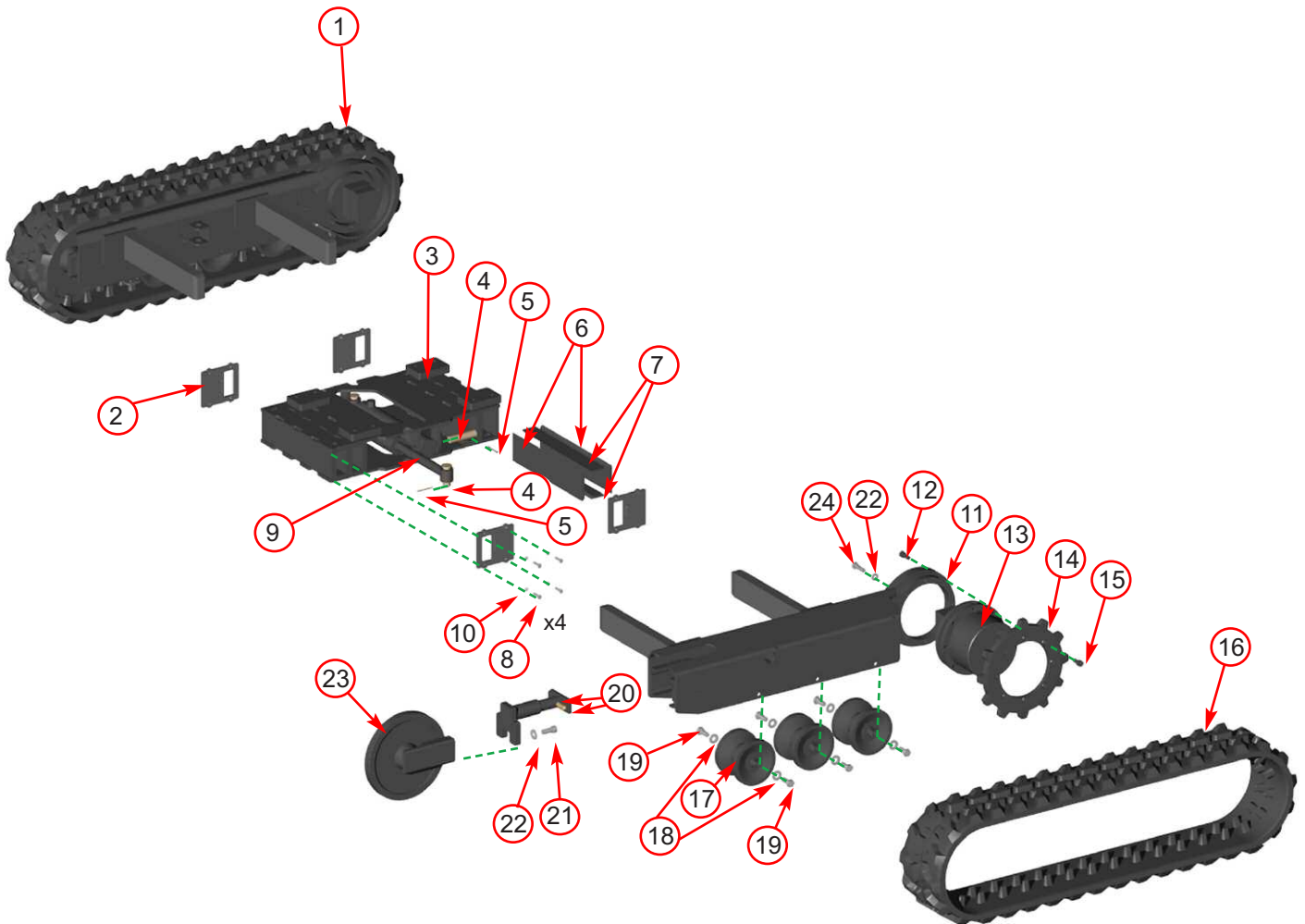

Item	Part No	Part Name	Q'ty	Item	Part No	Part Name	Q'ty
1	18952	Crawler Track Assy	2	13	18951	Motor Gear Box	2
2	3077FB	Slip Retainer	4	14	19035	Sprocket	2
3	3074FB	Variable Track Bridge	1	15	0373	M10/20 Caphead	16
4	18014MS	Cylinder Pin	4	16	19033	Rubber Track	2
5	1276	Split Pin	4	17	19034	Bottom Roller	6
6	4045	Plastic Strip	8	18	0704	M12 C Washer	12
7	4044	Plastic Strip	8	19	0321	M12/30 Bolt	12
8	18105	M5/20 Bolt	16	20	19036	Adjuster/Tensioner	2
9	4046	Hydraulic Cylinders	2	21	0382	M10/30 Bolt	4
10	0708	M5 C Washer	16	22	0701	M10 A Washer	4
11	18955	VTR Track Frame (handed pair)	1	23	19037	Idler Wheel	2
12	1629	M10/25 Caphead	14	24	4068	M10/40 Bolt	2

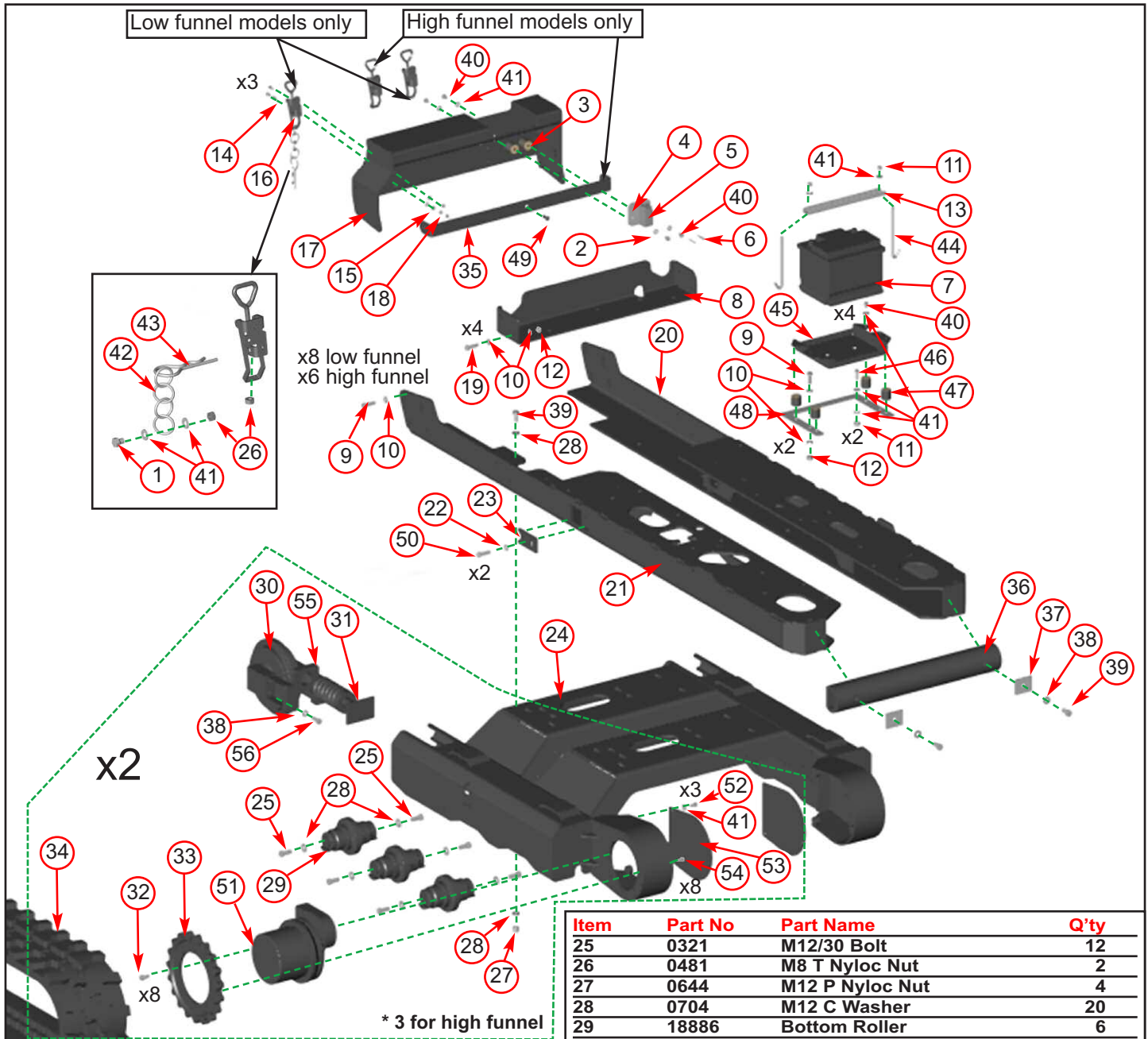

Item	Part No	Part Name	Q'ty
1	0346	M8/20 Bolt	2
2	0711	M8 A Washer	2
3	1868	M8 AV Mount	2
4	1691FS	Switch Back Plate	1
5	1692	Limit Switch	1
6	18168	M4/35 Pan Pozi	2
7	4210	Battery	1
8	3042FB	Chassis Bridge	1
9	0360	M10/25 Bolt	18
10	0701	M10 A Washer	20
11	0479	M8 P Nyloc Nut	4
12	0052	M10 T Nyloc Nut	4
13	18040FS	Battery Clamp	1
14	0256	M5/16 Csk Socket Screw	6*
15	0708	M5 C Washer	6*
16	4092	Draw Latch <i>High Funnel 1, Low Funnel 2</i>	2
17	3010FB	Funnel Support	1
18	18102	M5 T Nyloc Nut	6*
19	1812	M10/35 Bolt	4
20	2990F	Near Side Beam	1
21	2991F	Off Side Beam	1
22	0839	M10 C Washer	2
23	4008B	Jacking Beam Cover	1
24	P*799F	Track Bridge	1

Item	Part No	Part Name	Q'ty
25	0321	M12/30 Bolt	12
26	0481	M8 T Nyloc Nut	2
27	0644	M12 P Nyloc Nut	4
28	0704	M12 C Washer	20
29	18886	Bottom Roller	6
30	18890	Idler Wheel	2
31	18889	Adjuster/Tensioner	2
32	18124	M10/20 Caphead	8
33	18888	Sprocket	2
34	18885FB	Rubber Track	2
35	4106FB	Tank Stop Bar	1
36	2930	Rubber Buffer	1
37	4067S	D Rubber Fixing Plate	1
38	0702	M12 A Washer	4
39	0431	M12/40 Bolt	6
40	18037	M8/12 Bolt	6
41	0712	M8 C Washer	18
42	4105	Chain 40 x 16 x 3.8	2
43	4094	R Clip 5 mm x 85	2
44	18041	M8 x 170 Hook Bolt	2
45	18039FB	Battery Tray	1
46	0350	M8/25 Bolt	2
47	1644	AV Mount	4
48	18038FS	Battery Base Plate	1
49	0347	M8/20 Button Head	1
50	0382	M10/30 Bolt	2
51	18810	Motor Gear Box	2
52	0344	M8/16 Bolt	3
53	P*930	Guard	2
54	0305	M10/25 Caphead	8
55	18891	Idler Wheel Bracket	2
56	1985	M12/30 Caphead	2

* 3 for high funnel

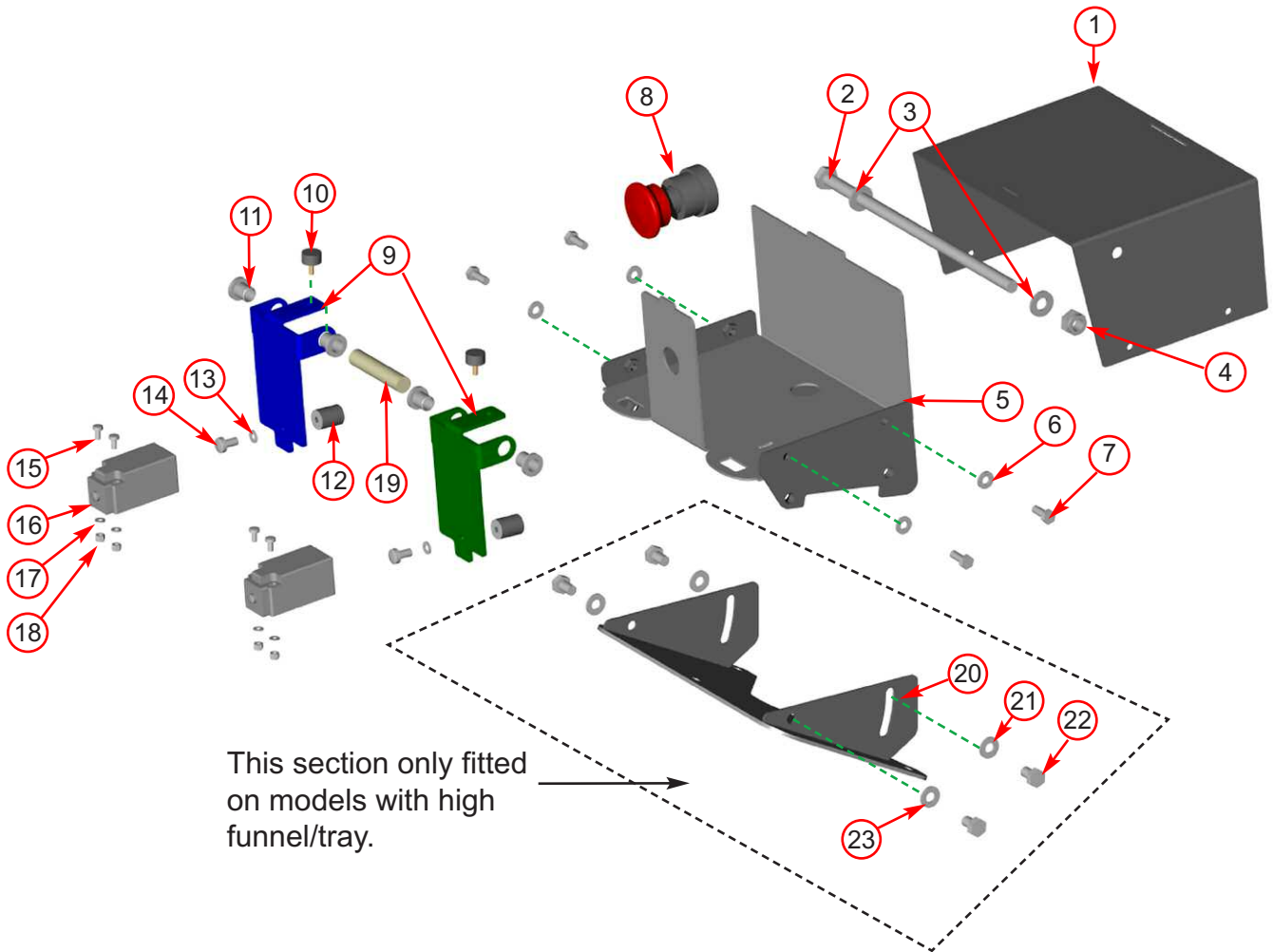

This section only fitted
on models with high
funnel/tray.

Item	Part No	Part Name	Q'ty	Item	Part No	Part Name	Q'ty
1	2794FB	Control Box Cover	1	13	0857	M5 A Washer	2
2	2803	M10/240 Bolt	1	14	18103	M5/8 Pan Pozi	2
3	0839	M10 C Washer	2	15	18168	M4/35 Pan Pozi	4
4	4345	M10 P Nyloc Nut	1	16	1348	Limit Switch	2
5	2795FB	Control Box Base	1	17	18100	M4 Washer	6
6	0709	M6 C Washer	4	18	18235	M4 P Nyloc Nut	6
7	1658	M6/12 Bolt	4	19	made in production	65mm Spacer	1
8	2853	Stop Switch	1	20	2793FB	Bracket Mounting Control Box	1
9	2796FS	Finger Plate	2	21	0712	M8 C Washer	2
10	2834	AV Mount	2	22	0344	M8/16 Bolt	4
11	2804	Bush M10 Top Hat	4	23	0711	M8 A Washer	2
12	2807	AV Mount 20 x 16	2				



LOW FUNNEL ONLY

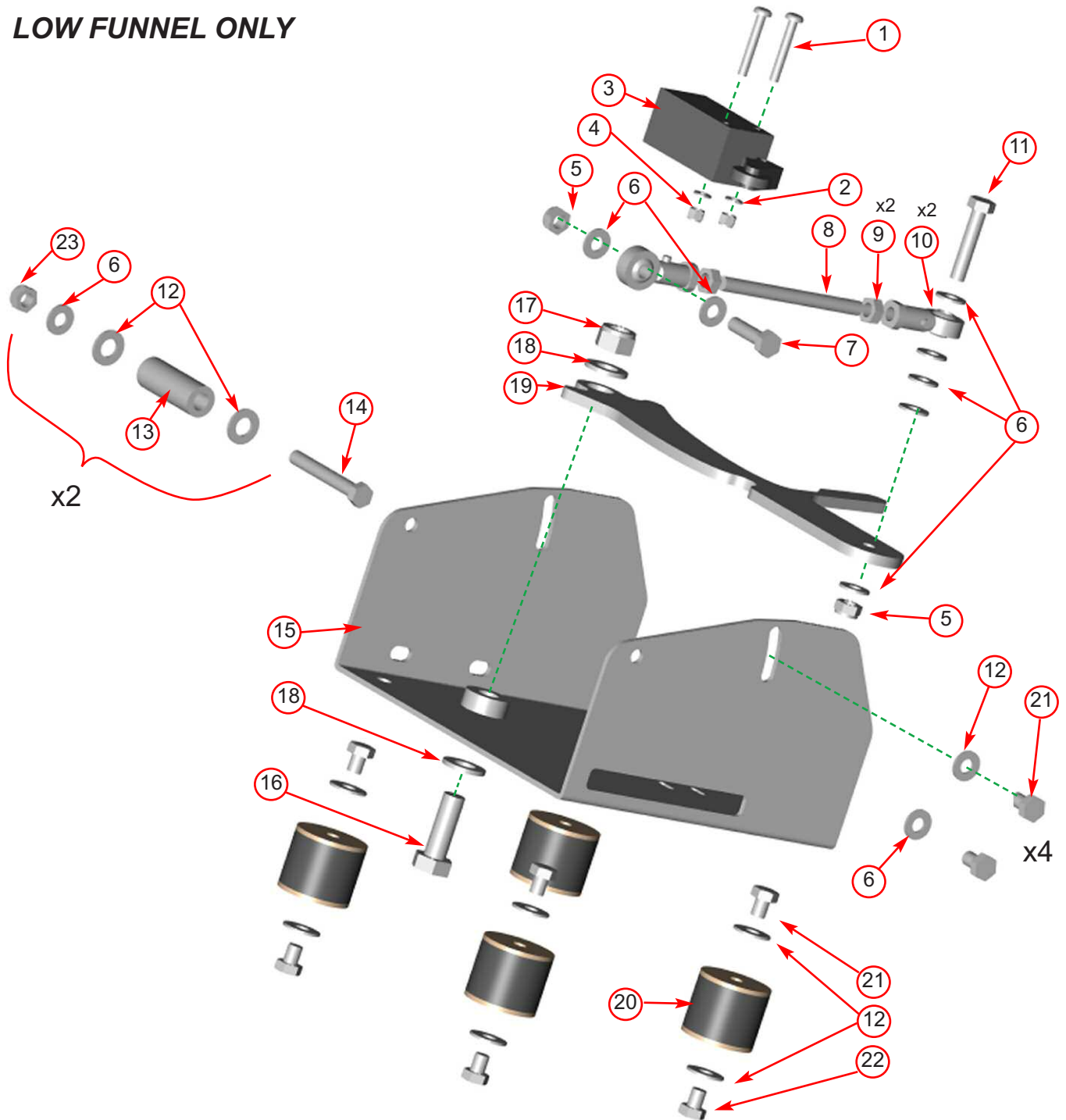

Item	Part No	Part Name	Q'ty	Item	Part No	Part Name	Q'ty
1	18168	M4/35 Pan Pozi	2	13	1603	Spring	2
2	18100	M4 A Washer	2	14	18119	M8/70 Bolt	2
3	1692	Limit Switch	1	15	3055FB	Link Mechanism Casing	1
4	18235	M4 P Nyloc Nut	2	16	0431	M12/40 Bolt	1
5	0481	M8 T Nyloc Nut	2	17	0045	M12 T Nyloc Nut	1
6	0711	M8 A Washer	13	18	0702	M12 A Washer	2
7	0351	M8/30 Bolt	1	19	3058PS	Link Mechanism Arm	1
8	made in production	M8 Threaded Rod	1	20	1868	AV Mount	4
9	0476	M8 Plain Nut	2	21	18037	M8/12 Bolt	4
10	0925	Rose Joint Rod End	2	22	1721	M8/10 Bolt	8
11	18117	M8/35 Bolt	1	23	0479	M8 P Nyloc Nut	2
12	0712	M8 C Washer	12				

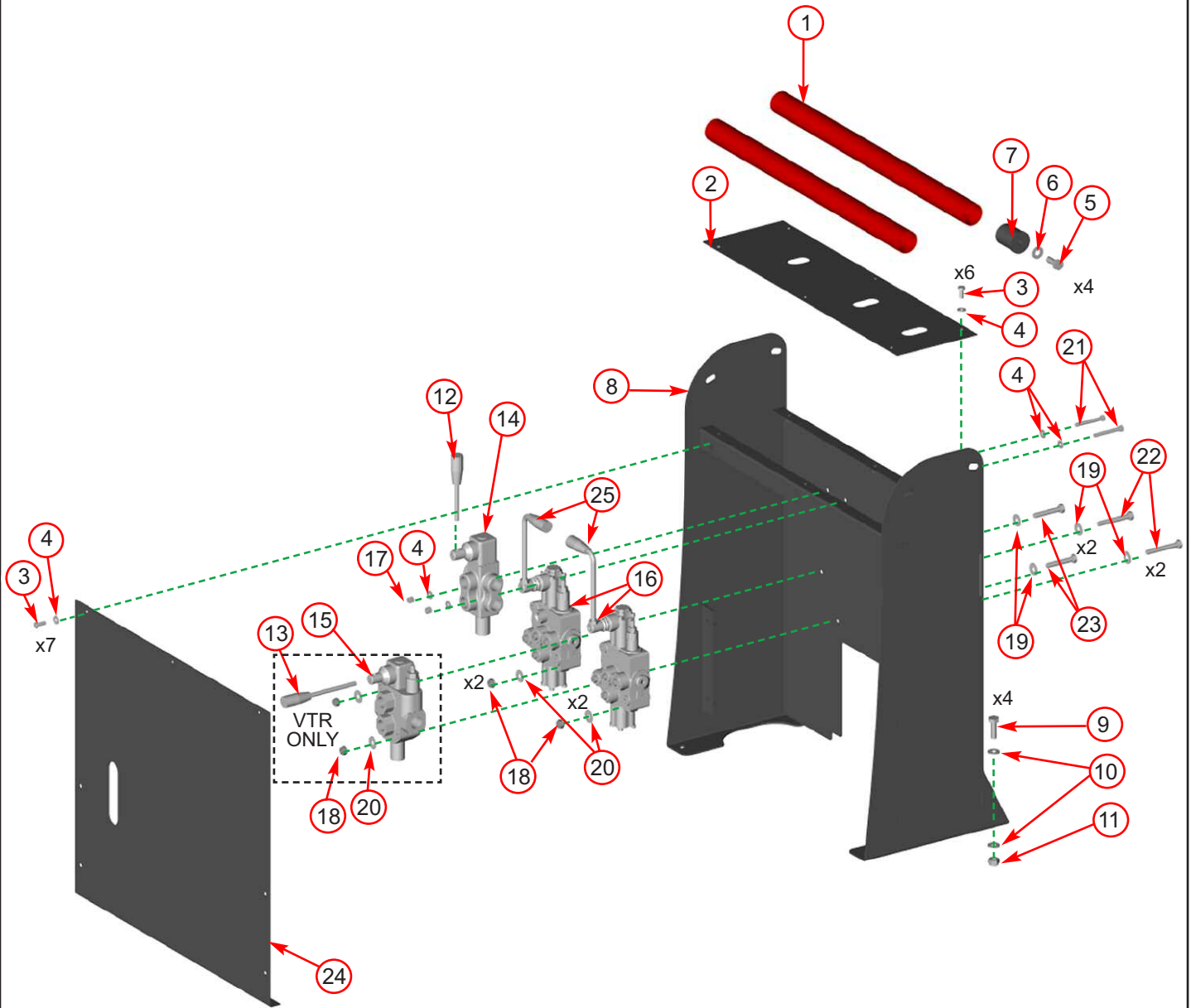

Item	Part No	Part Name	Q'ty
1	1802FR	Cross Bar	2
2	1879FB	Control Panel Tracked	1
3	0437	M6/16 Bolt	13
4	0709	M6 C Washer	17
5	0360	M10/25 Bolt	4
6	0701	M10 A Washer	4
7	1803P	End Plug	4
8	1883FB	Control Tower Tracked	1
9	0382	M10/30 Bolt	4
10	0839	M10 C Washer	8
11	0052	M10 T Nyloc Nut	4
12	1860	M8 Lever	1
13	1737	M8 Lever	1

Item	Part No	Part Name	Q'ty
14	1738	Six Way Diverter Valve	1
15	3005	Four Port Valve	1
16	P*24	Proportional Crossover Valve	2
17	0142	M6 P Nyloc Nut	2
18	0481	M8 T Nyloc Nut	6
19	0712	M8 C Washer	6
20	0711	M8 A Washer	6
21	0341	M6/50 Bolt	2
22	0354	M8/60 Bolt	4
23	1319	M8/50 Bolt	2
24	1882FB	Hose Guard	1
25	18850F	L-shaped Track Handle	2

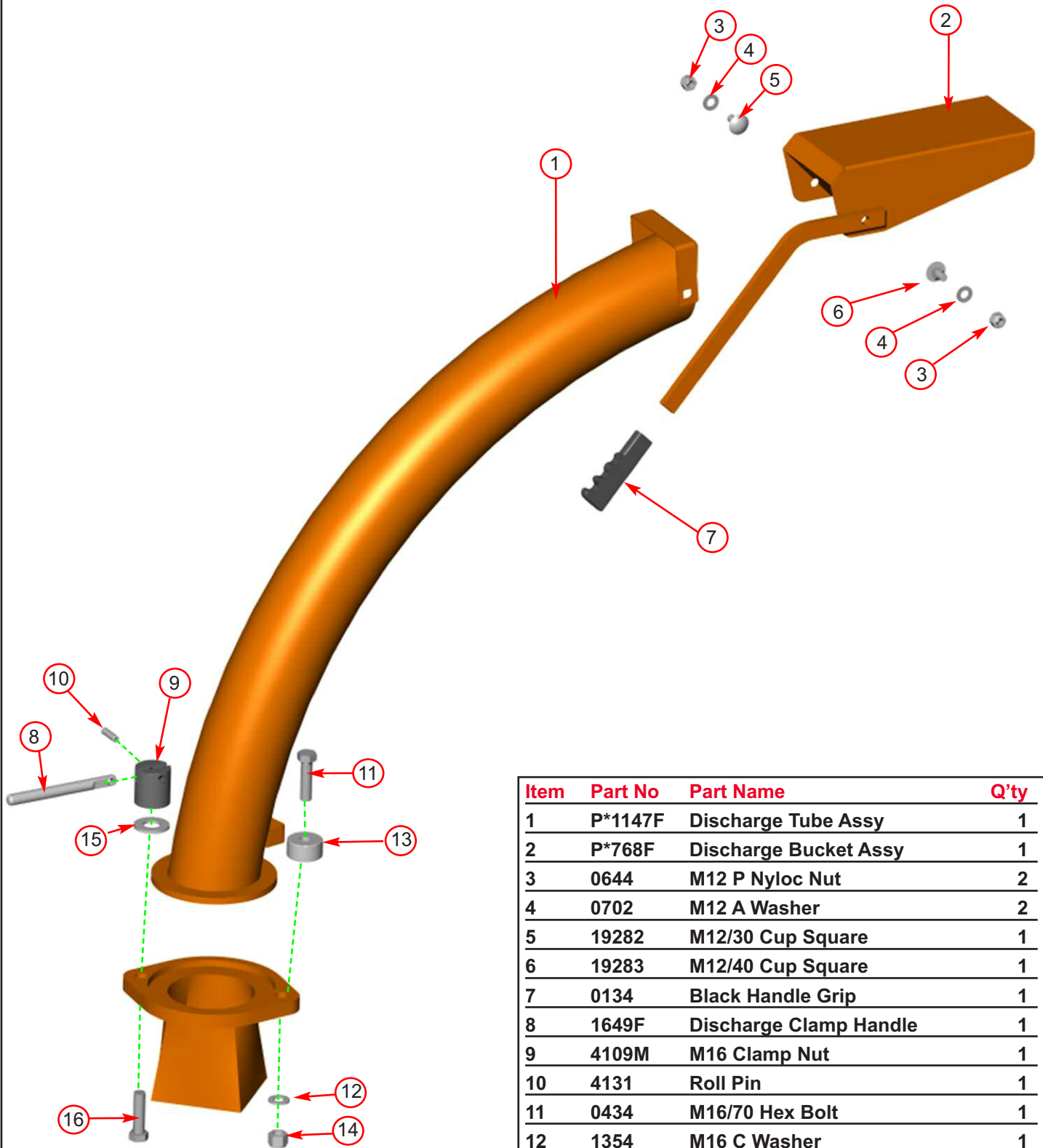

Item	Part No	Part Name	Q'ty
1	P*1147F	Discharge Tube Assy	1
2	P*768F	Discharge Bucket Assy	1
3	0644	M12 P Nyloc Nut	2
4	0702	M12 A Washer	2
5	19282	M12/30 Cup Square	1
6	19283	M12/40 Cup Square	1
7	0134	Black Handle Grip	1
8	1649F	Discharge Clamp Handle	1
9	4109M	M16 Clamp Nut	1
10	4131	Roll Pin	1
11	0434	M16/70 Hex Bolt	1
12	1354	M16 C Washer	1
13	2837M	Clamp Nut Small	1
14	1511	M16 P Nyloc Nut	1
15	18190	M24 Washer	1
16	0333	M16/60 Hex Bolt	1

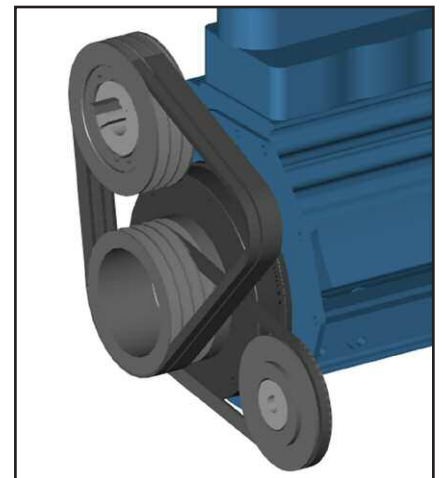
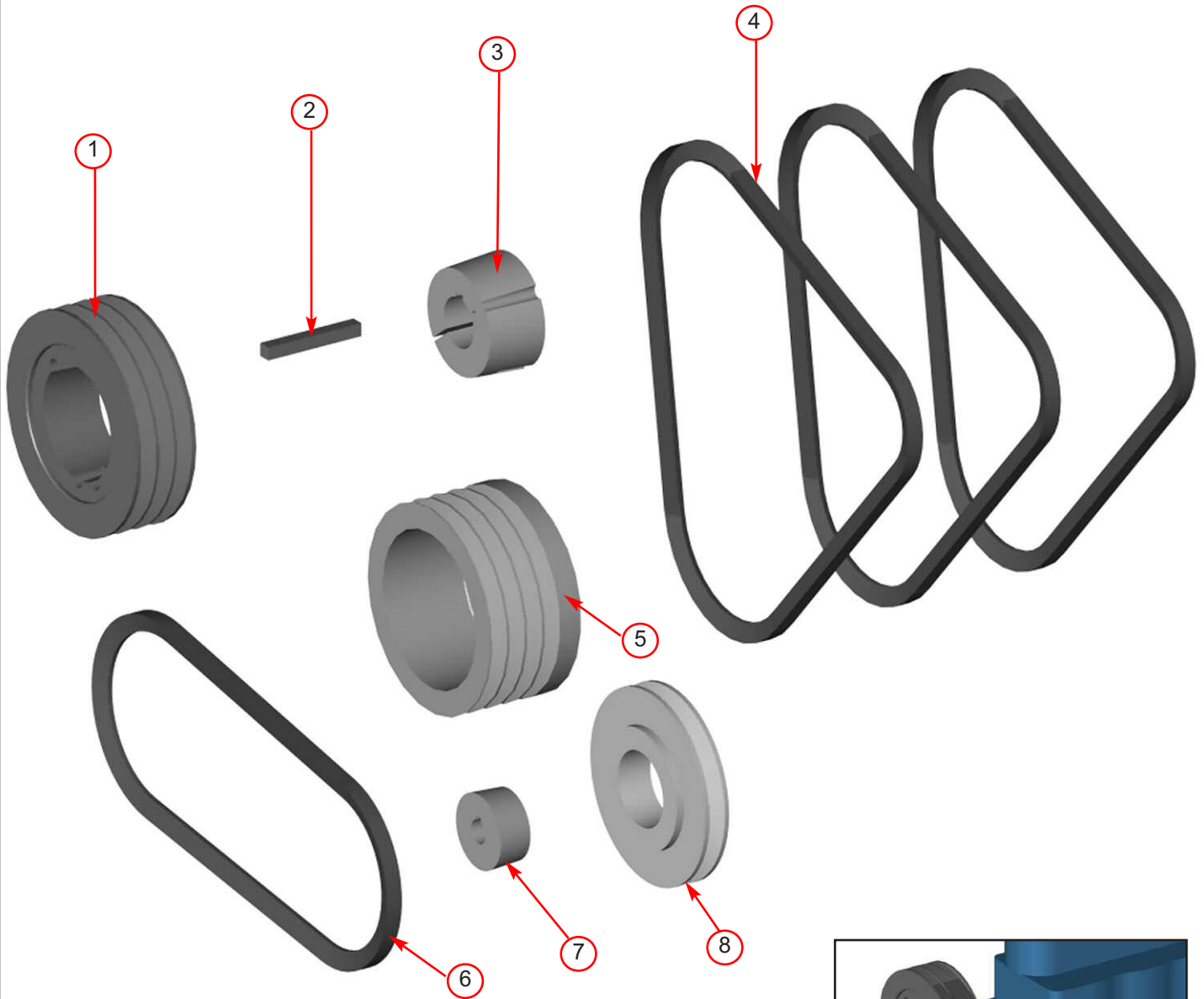

Item	Part No	Part Name	Q'ty	Item	Part No	Part Name	Q'ty
1	1175	Rotor Pulley	1	5	1170M	Engine Pulley	1
2	18961M	Key	1	6	1533	Vee Belt SPA 900	1
3	1410	Taper Lock Bush 2517	1	7	2975	Taper Lock Bush 1610 18 mm	1
4	0310	Belt SPA 1060	3	8	0949	Pulley 140 x 1 SPA	1

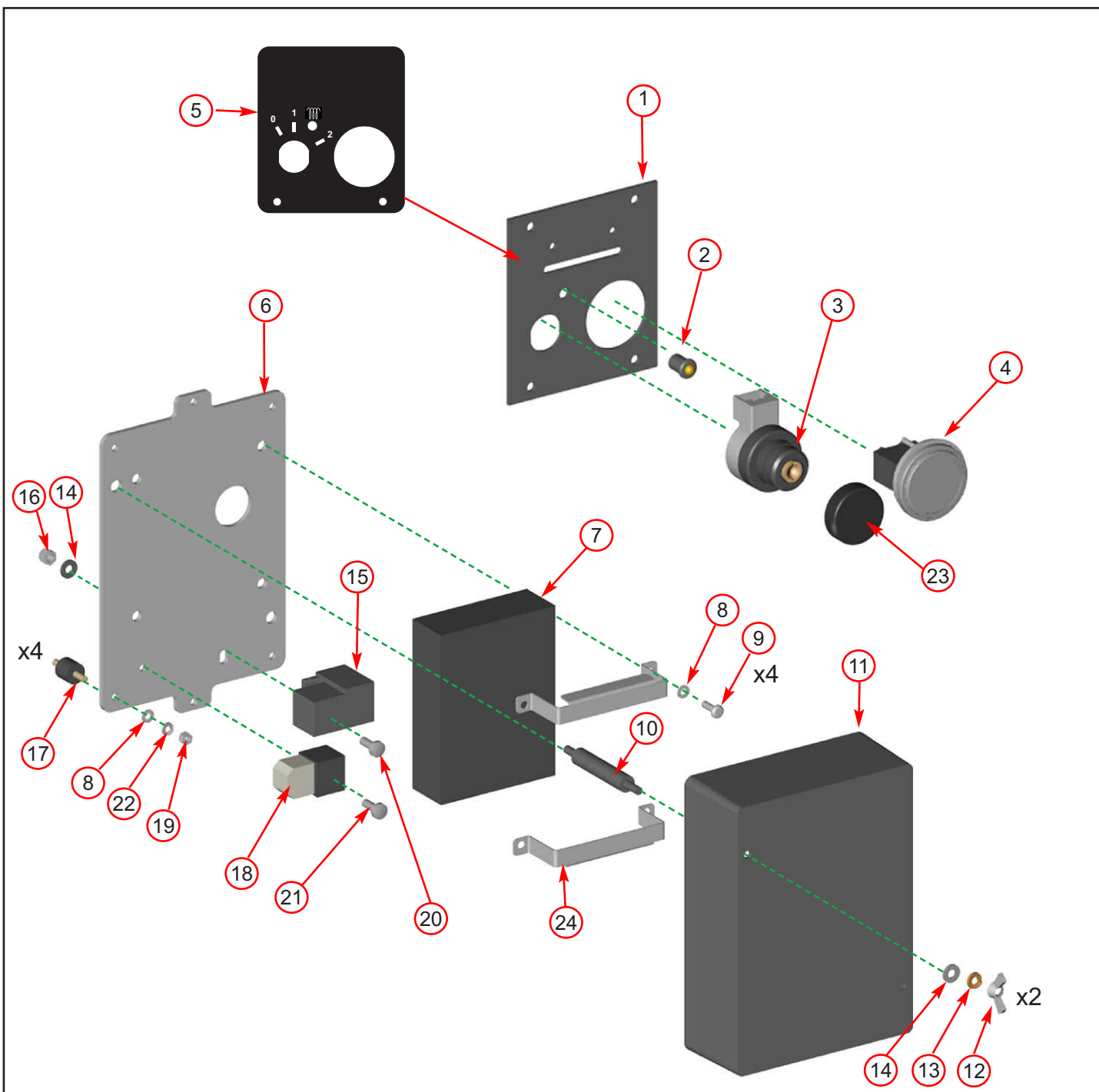

Item	Part No	Part Name	Q'ty	Item	Part No	Part Name	Q'ty
1	1758S	Control Panel	1	13	18106	M6 Spring Washer	2
2	1757	Amber LED	1	14	0709	M6 C Washer	4
3	Supp'd with engine	Ignition Switch	1	15	Supp'd with loom	Relay	1
4	0327	Hours Counter	1	16	0391	M6 T Nyloc Nut	2
5	18008	Control Panel Decal	1	17	4033	M5 AV Mount	4
6	3038FS	Electrical Panel	1	18	Supp'd with loom	Fuse	2
7	18405	H-Box	1	19	0236	M5 P Nyloc Nut	4
8	0857	M5 A Washer	8	20	0438	M6/16 Pan Pozi	1
9	0435	M5/16 Pan Pozi	4	21	1151	Countersunk Pop Rivet	1
10	2725	Electrical Cover Stand Off	2	22	3024	M5 Spring Washer	4
11	1930	Electrical Cover	1	23	1470	Rubber Protector	1
12	18107	M6 Wing Nut	2	24	18398	Mounting Bracket	4

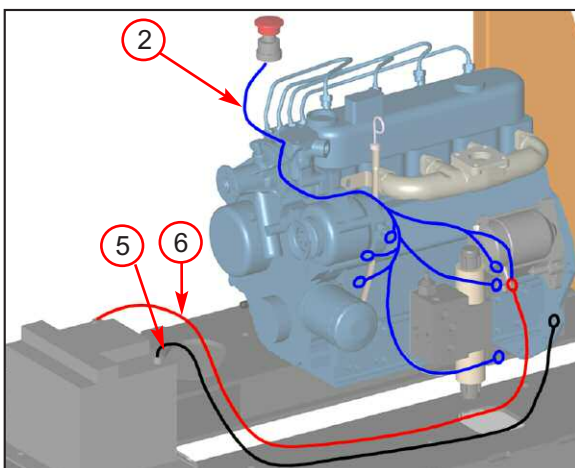
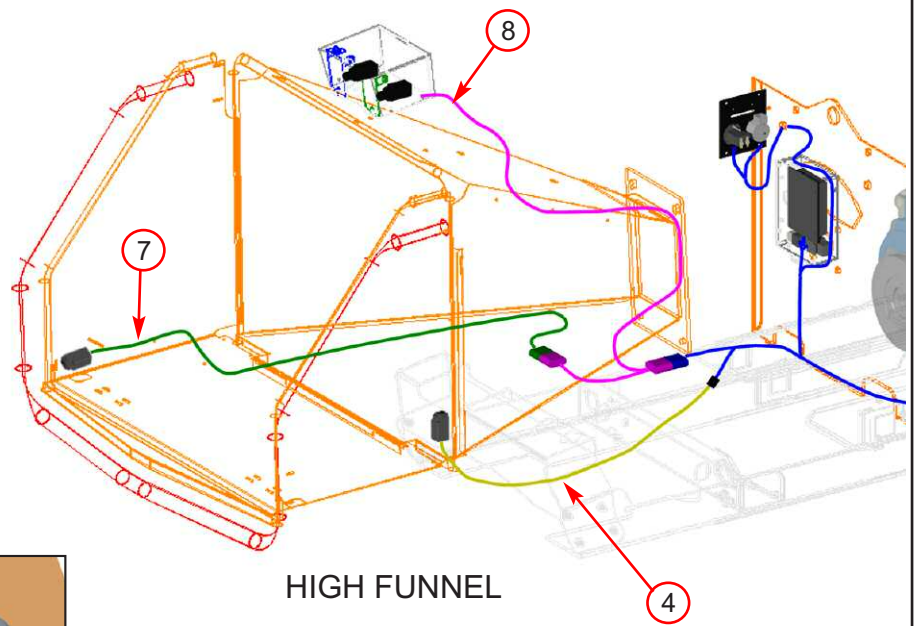
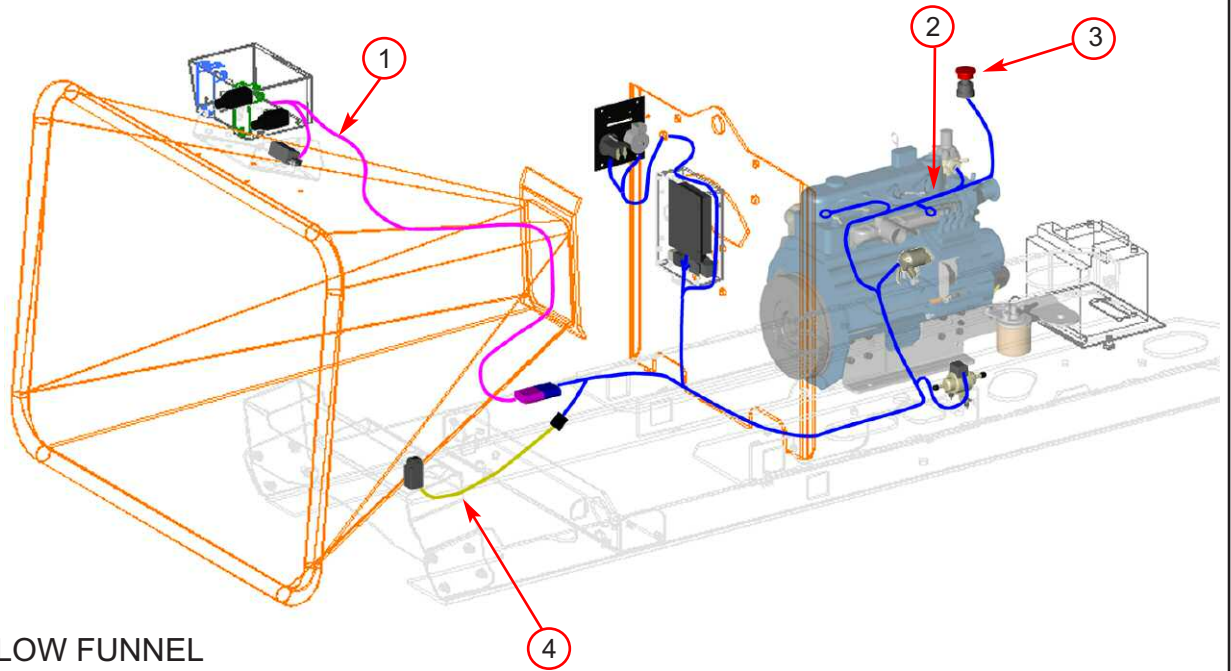

Item	Part No	Part Name	Q'ty	Item	Part No	Part Name	Q'ty
1	3019	Control Box Loom	1	5	1376	-VE Battery Cable	1
2	18481	Engine Loom	1	6	1375	+VE Battery Cable	1
3	2627	Emergency Stop Switch	1	7	1406	Safety Bar Loom	1
4	4017	Safety Switch Loom	1	8	1975	Control Box Loom	1

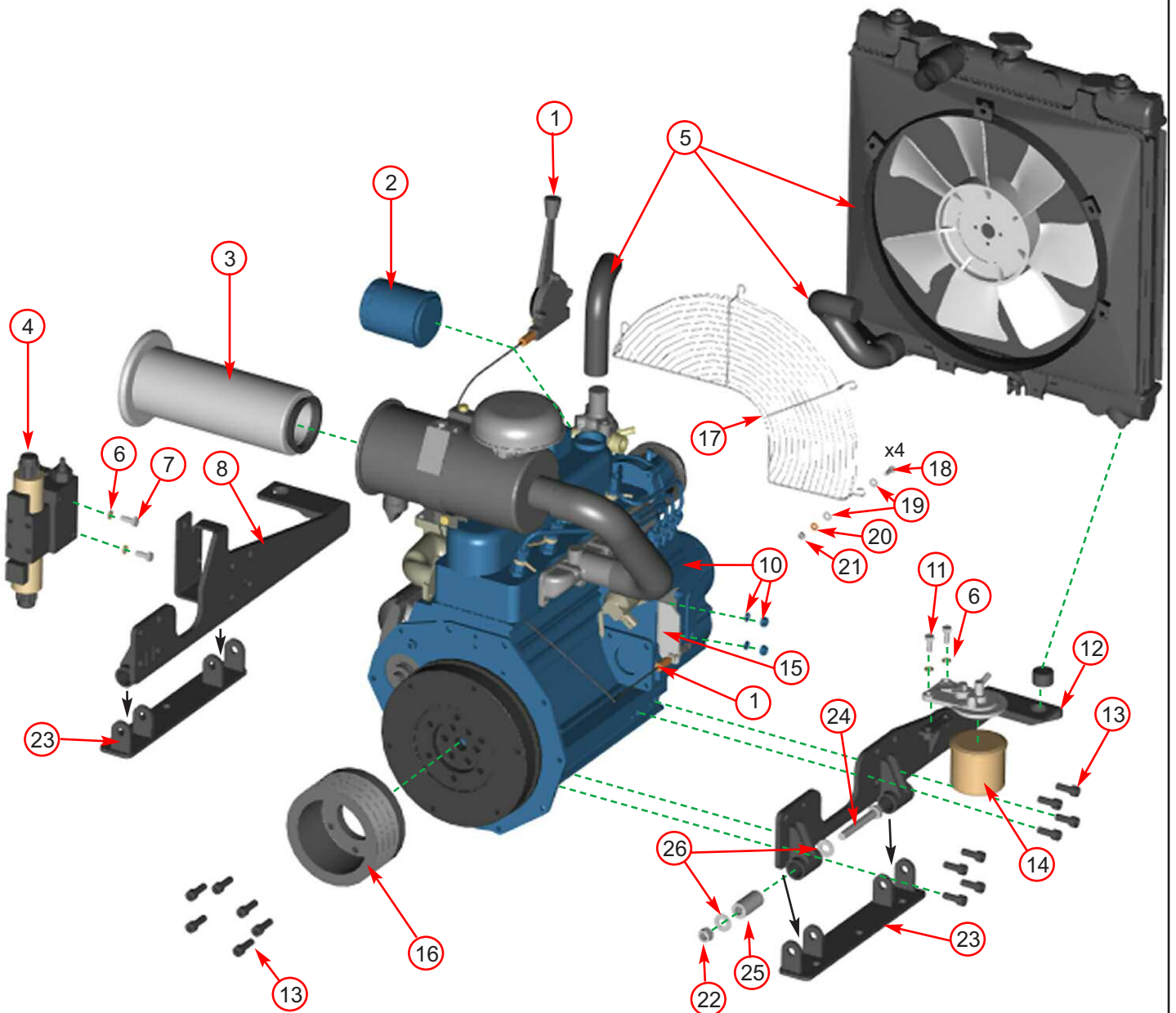

Item	Part No	Part Name	Q'ty
1	2946	Throttle Cable	1
2	0095	Oil Filter	1
3	0086	Air Filter	1
4	4252	Directional Control Valve	1
5	4319	Radiator Kit	1
6	0711	M8 A Washer	4
7	0346	M8/20 Bolt	2
8	19156FB	Engine Bracket Nearside	1
9	1170	Pulley Engine 150 x 4	1
10	0879	Engine	1
11	0350	M8/25 Bolt	2
12	19155FB	Engine Bracket Offside	1
13	0304	M10/25 Fine Thread Socket Cap	22

Item	Part No	Part Name	Q'ty
14	0085	Fuel Filter	1
15	2954	Throttle Cable Bracket	1
16	1170M	Pulley Engine 168 x 4	1
17	4335	Radiator Fan Guard	1
18	0437	M6/16 Bolt	4
19	0709	M6 C Washer	8
20	18106	M6 Spring Washer	4
21	0392	M6 Plain Nut	4
22	0644	M12 P Nyloc Nut	4
23	18338FS	Engine Bracket Base	2
24	0332	M12/90 Bolt	4
25	18332	AV Mount	4
26	0704	M12 C Washer	4

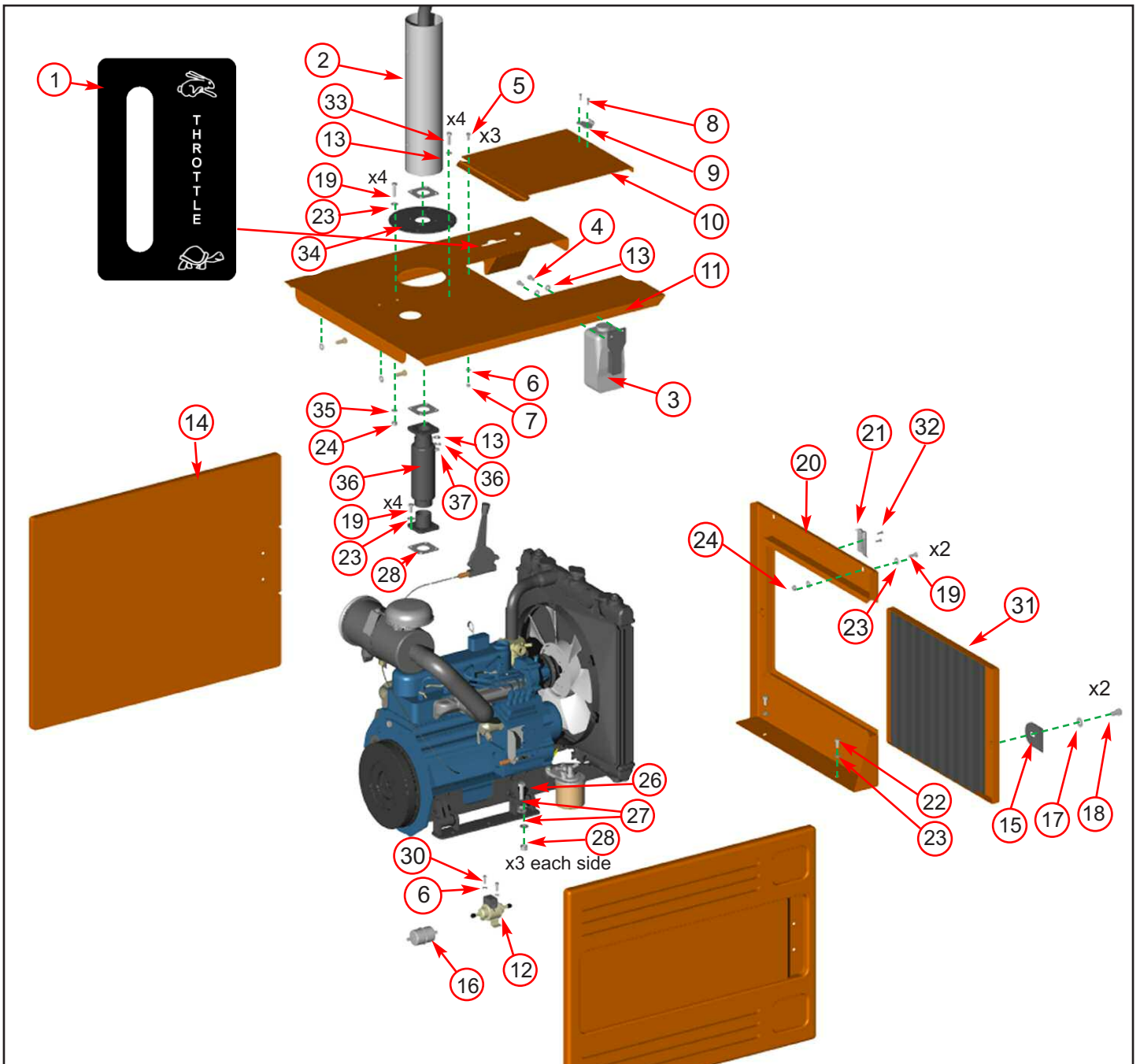

Item	Part No	Part Name	Q'ty	Item	Part No	Part Name	Q'ty
1	2950	Throttle Decal	1	19	0346	M8/20 Bolt	10
2	18915F	Exhaust Muffler Complete	1	20	18580FO	Front Engine Bay Guard	1
3	4320	Reserve Tank	1	21	0235	Catch	1
4	0344	M8/16 Bolt	2	22	0350	M8/25 Bolt	2
5	0438	M6/16 Pan Pozi	3	23	0712	M8 C Washer	12
6	0709	M6 C Washer	5	24	1757	M8 P Nyloc Nut	6
7	0142	M6 P Nyloc Nut	3	25	0431	M12/40 Bolt	6
8	0066	Pop Rivet 5 x 6	2	26	1008	Spring Washer	4
9	4088	Catch Plate	1	27	0476	M8 Plain Nut	4
10	0607FO	Access Cover	1	28	17988	Gasket	3
11	17292FO	Top Bonnet	1	29	0644	M12 P Nyloc Nut	6
12	0807	Fuel Pump	1	30	0437	M6/16 Bolt	2
13	0711	M8 A Washer	10	31	18581FO	Shroud Radiator with Grille	1
14	0765O	Side Panel	2	32	0067	Pop Rivet 4.8 x 12	2
15	2836FO	Engine Guard Retainer	2	33	18117	M8/35 Bolt	4
16	4315	In-Line Fuel Filter	1	34	18851	Muffler Plate	1
17	0704	M12 C Washer	14	35	19092	Flexi Adaptor	1
18	0318	M12/20 Bolt	2	36	0714	M8 Mudguard Washer	1

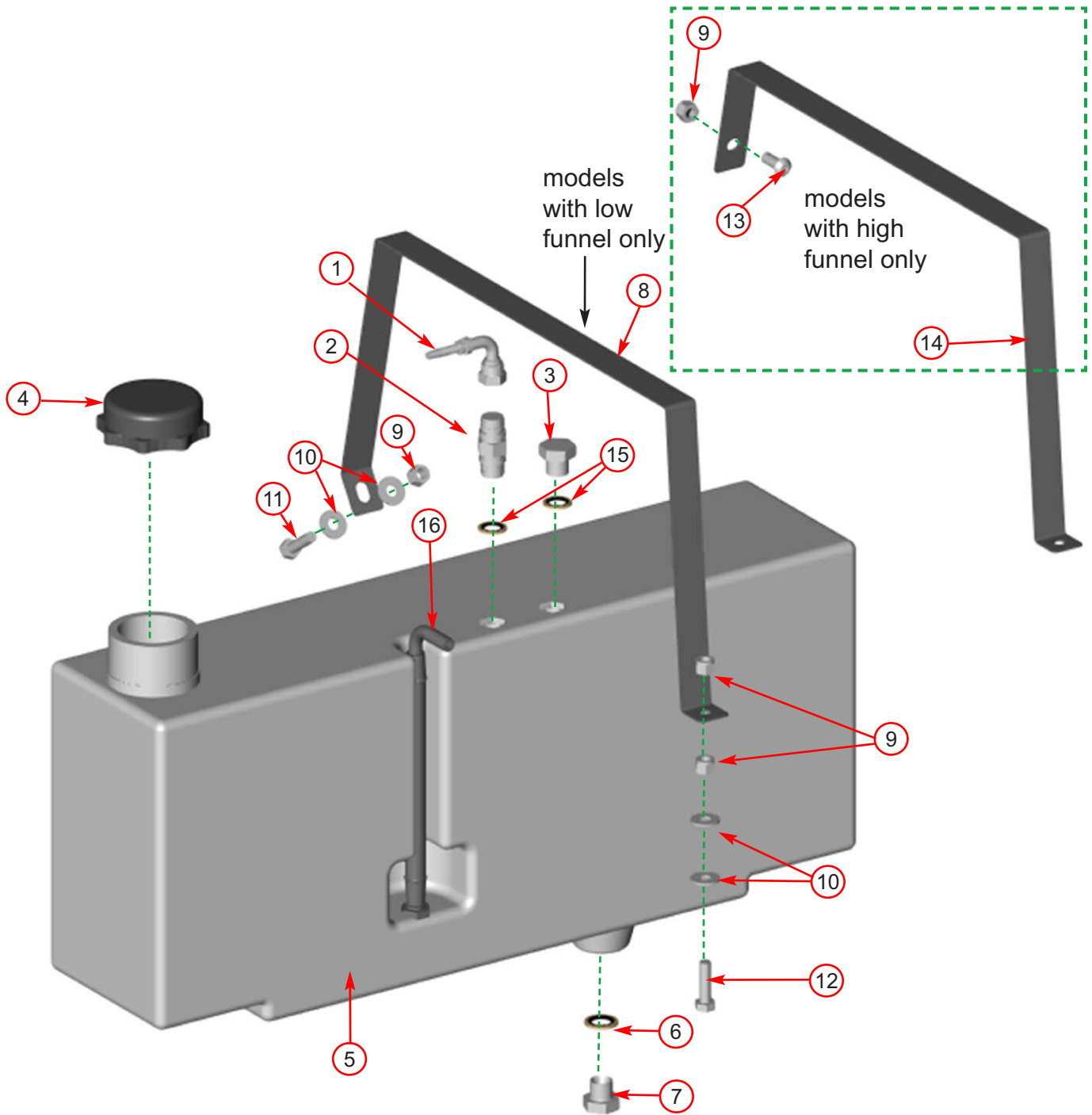

Item	Part No	Part Name	Q'ty
1	19430	1/4" BSP tail	1
2	18883	1/4" MM Adapter	1
3	0296	1/4" Blanking Plug	1
4		Locking Tank Cap	1
5	P*814	Fuel Tank Kit	1
6	0396	3/8" Dowty Washer	1
7	0211	3/8" Drain Plug	1
8	4087F	Tank Strap	1

Item	Part No	Part Name	Q'ty
9	1757	M8 P Nyloc Nut	4
10	0712	M8 C Washer	4
11	0346	M8/20 Bolt	1
12	0351	M8/30 Bolt	1
13	0347	M8/20 Button Head	1
14	18042F	Tank Strap (short)	1
15	0795	1/4" Dowty Washer	2
16	P*815	Hose Fuel Pick Up	1

FUNNEL (HIGH)



TIMBERWOLF
TW 150VTR/FTR

51

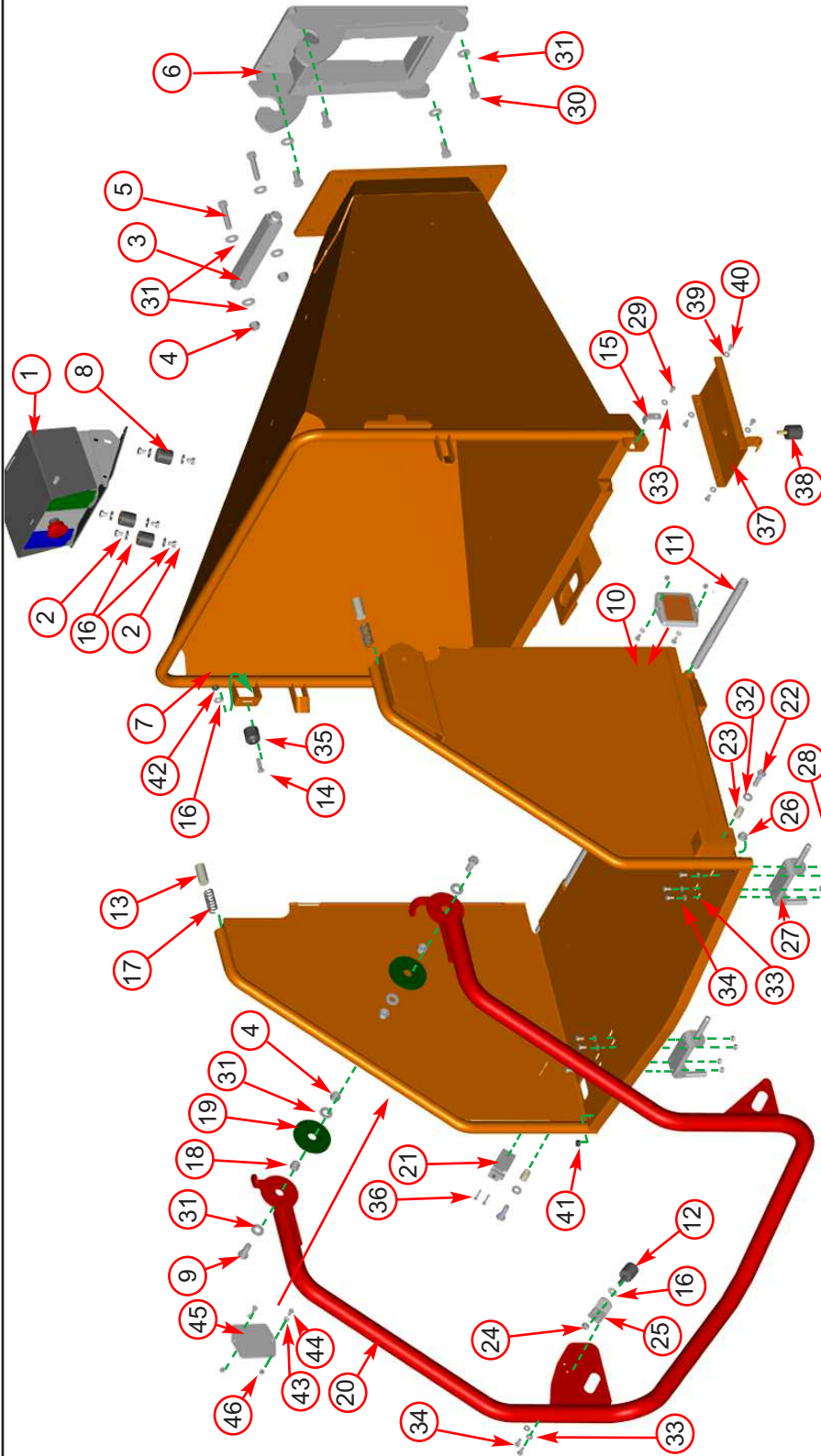

Item	Part No	Part Name	Q'ty	Item	Part No	Part Name	Q'ty	Item	Part No	Part Name	Q'ty
1	2809F	Control Box (detail on pages 39/40)	1	17	1603	Die Springs	2	33	0709	M6 C Washer	12
2	1721	M8/10 Bolt	6	18	1605M	Stainless Spacer	2	34	0437	M6/16 Bolt	10
3	4282MS	Quick Release Pivot Bar	1	19	1599	Bearing Washer	2	35	4206	Nylon Bush	1
4	0045	M12 T Nyloc	4	20	1570FR	Safety Bar	1	36	1006	M4/30 Pan Pozi	2
5	18173	M12/55 Bolt	2	21	1348	Limit Switch	1	37	4107FO	Retro High Funnel Bracket	1
6	4283F	Quick Release Mechanism	1	22	1520	M10/45 Bolt	2	38	17421	AV Mount	1
7	4238FO	Funnel	1	23	1591	Nylon Spacer	2	39	0709	M6 C Washer	4
8	1644	M8 Anti-Vibration Mount	3	24	0479	M8 P Nyloc Nut	1	40	0439	M6/20 Hex Screw	4
9	0429	M12/35 Bolt	2	25	2727FS	Bracket Actuator	1	41	2493	Rubber Cap	2
10	2919FO	Feed Tray	1	26	4345	M10 P Nyloc Nut	2	42	0481	M8 T Nyloc Nut	1
11	2922FS	Hinge Pin	2	27	2986	1/2" Spring Bolt	2	43	18104	M5/12 Pan Pozi	4
12	0178	Rubber End Stop	1	28	0391	M6 T Nyloc Nut	8	44	0857	M5 A Washer	4
13	1600	Nylon Pistons	2	29	1236	M6/20 Bolt	2	45	18924	Square Reflector	2
14	4342	M8/30 Csk Soc.	1	30	0321	M12/30 Bolt	4	46	18102	M5 T Nyloc Nut	2
15	4018S	Pin Bracket	2	31	0704	M12 C Washer	12				
16	0712	M8 C Washer	8	32	4344	M10 Repair Washer	2				

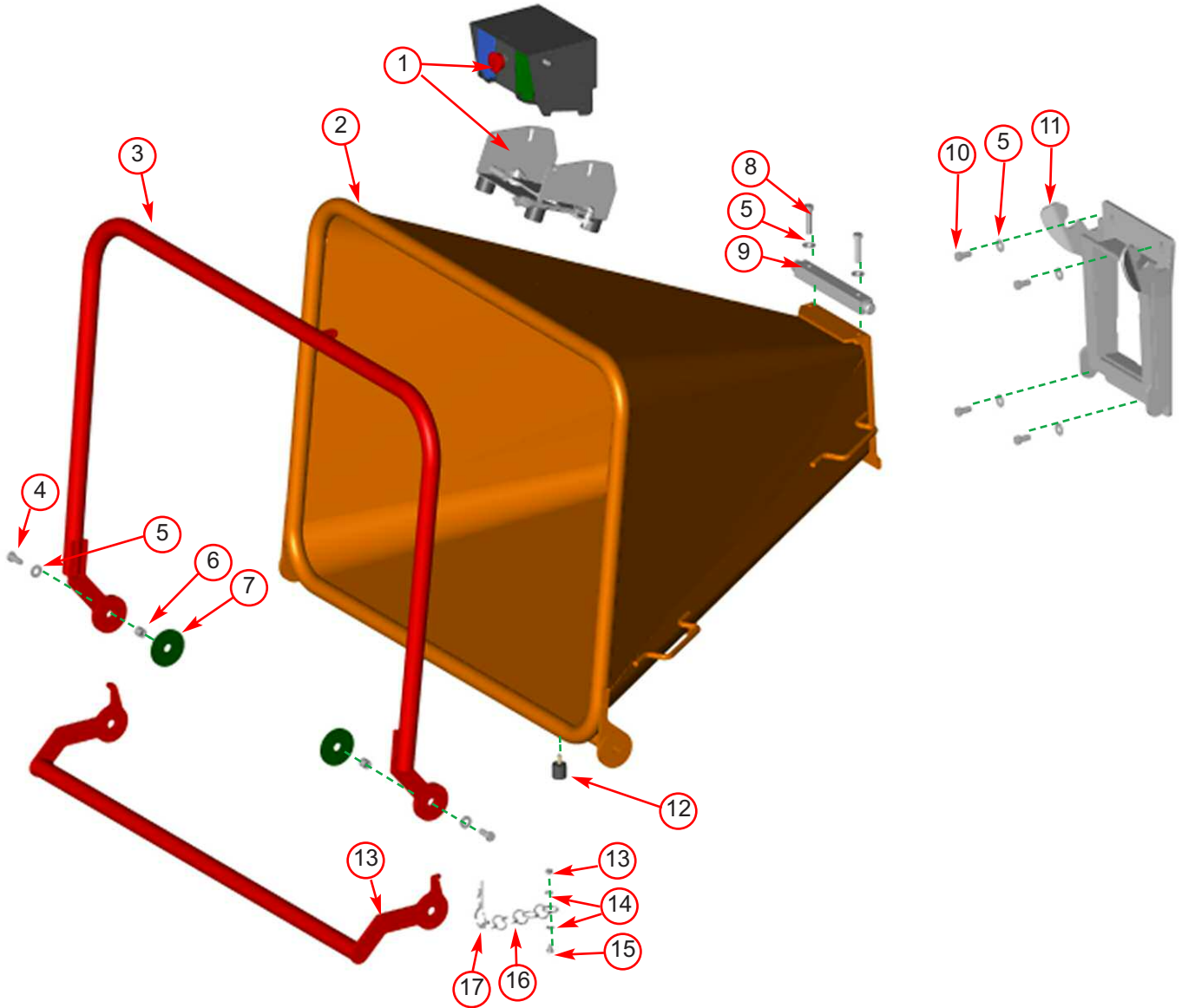

Item	Part No	Part Name	Q'ty
1	See pages 38/39	Control Box	1
2	3008FO	Funnel	1
3	18507FR	Safety Bar	1
4	0431	M12/40 Bolt	2
5	0704	M12 C Washer	8
6	4116M	Spacer Tube	2
7	1599	Bearing Washer	2
8	18173	M12/55 Bolt	2
9	4282MS	Quick Release Pivot Bar	1

Item	Part No	Part Name	Q'ty
10	0277	M12/25 Bolt	4
11	4283FO	Quick Release Mechanism	1
12	17421	AV Mount	1
13	18506FR	Underslung Safety Bar	1
14	0142	M6 T Nyloc Nut	1
15	0709	M6 C Washer	2
16	1236	M6/20 Bolt	1
17	4105	Chain 40 x 16 x 3.8 (7 links)	1
18	4094	R Clip	1

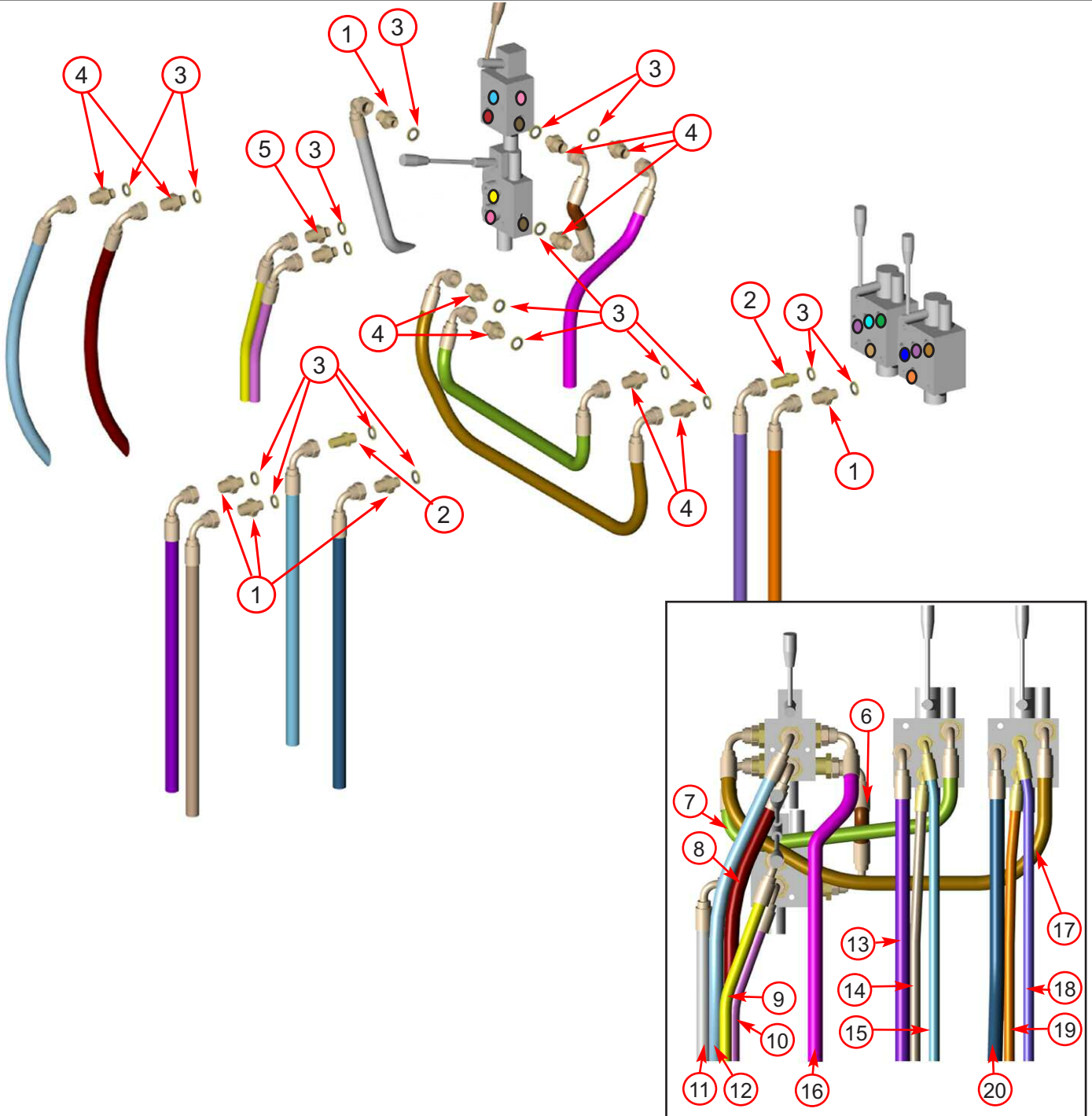

Item	Part No	Part Name	Q'ty
1	0161	3/8" - 3/8" Adapter	5
2	0828	3/8" Bulk Head Adapter	2
3	0396	3/8" Dowty Washer	18
4	0026	3/8" - 1/2" Adapter	9
5	0033	1/4" - 3/8" Adapter	2
6	3097	1/2" Hose, 6-way to 4-way valve	1
7	3095	1/2" Hose, 6-way to prop. valve	1
8	3099	1/2" Hose to pump front	1
9	3082	1/4" Hose, cylinder feed	1
10	3083	1/4" Hose, cylinder return	1

Item	Part No	Part Name	Q'ty
11	3084	3/8" Hose to manifold rear	1
12	4000	1/2" Hose to pump rear connection	1
13	3091	3/8" Hose to manifold	1
14	3089	3/8" Hose to bottom of track motor	1
15	3088	3/8" Hose to top of track motor	1
16	4240	1/2" Hose to DCV port 'P'	1
17	3096	1/2" Hose, 6-way to prop. valve	1
18	3087	3/8" Hose to top of track motor	1
19	3086	3/8" Hose to bottom of track motor	1
20	3090	3/8" Hose to manifold	1

54 HYDRAULICS-VTR (2)



TIMBERWOLF
TW 150VTR/FTR

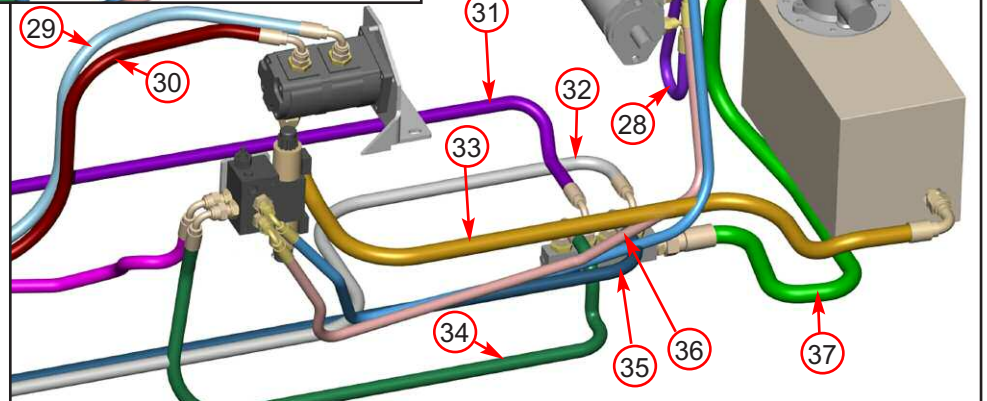
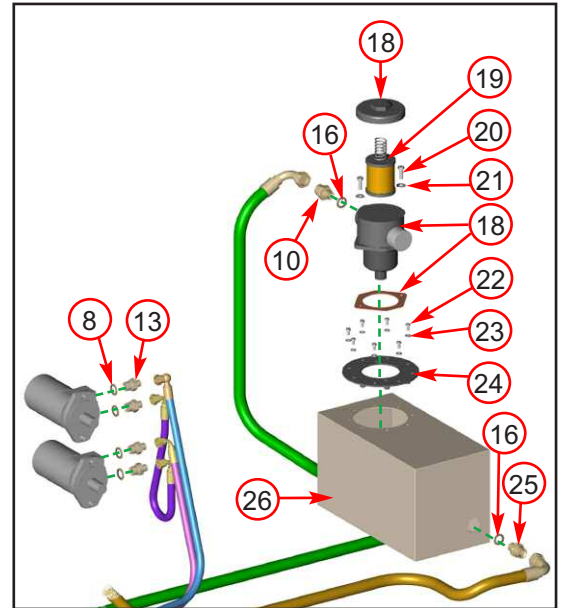
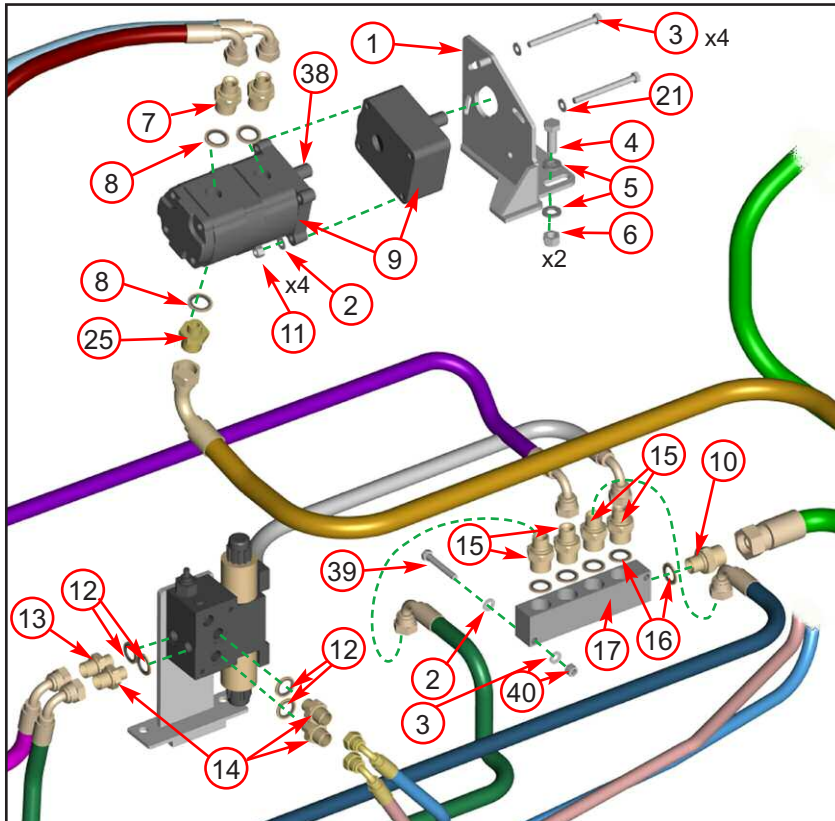

Item	Part No	Part Name	Q'ty
1	1913FS	Pump Bracket	1
2	0711	M8 A Washer	6
3	2988	M8/90 Bolt	6
4	0429	M12/35 Bolt	2
5	0702	M12 A Washer	4
6	0479	M12 P Nyloc Nut	2
7	0027	1/2" - 1/2" Adapter	2
8	0398	1/2" Dowty Seal	7
9	18893	Hydraulic Pump	1
10	0028	1/2"- 3/4" Adapter	2
11	0479	M8 P Nyloc Nut	4
12	0396	3/8" Dowty Seal	4
13	0026	3/8" - 1/2" Adapter	5
14	0161	3/8" - 3/8" Adapter	3
15	0225	3/4" - 3/8" Adapter	4
16	0152	3/4" Dowty Seal	7
17	1839MA	Manifold	1
18	1954	Tank Top Filter	1
19	0100	Filter Element	1
20	0350	M8/25 Bolt	2

Item	Part No	Part Name	Q'ty
21	0712	M8 C Washer	6
22	1658	M6/12 Bolt	8
23	0709	M6 C Washer	8
24	1702FS	Tank Top Plate	1
25	2694	3/4" - 1" Adapter	2
26	1703	Hydraulic Tank	1
27	17309	3/8" Hose, DCV to upper motor	1
28	3092	3/8" Hose, motor to motor	1
29	4000	1/2" Hose, pump rear to 6-way valve	1
30	3099	1/2" Hose, pump front to 6-way valve	1
31	3091	3/8" Hose, manifold to LH valve	1
32	3084	3/8" Hose, manifold to 4-port valve	1
33	4258	1" Hose, tank to pump front	1
34	4247	3/8" Hose, manifold to DCV	1
35	3090	3/8" Hose, manifold to RH valve	1
36	3094	3/8" Hose, DCV to lower motor	1
37	4303	1/2" Hose, manifold to hyd filter	1
38	18508	Pump Spine	1
39	0354	M8/60 Bolt	2
40	0479	M8 P Nyloc Nut	2

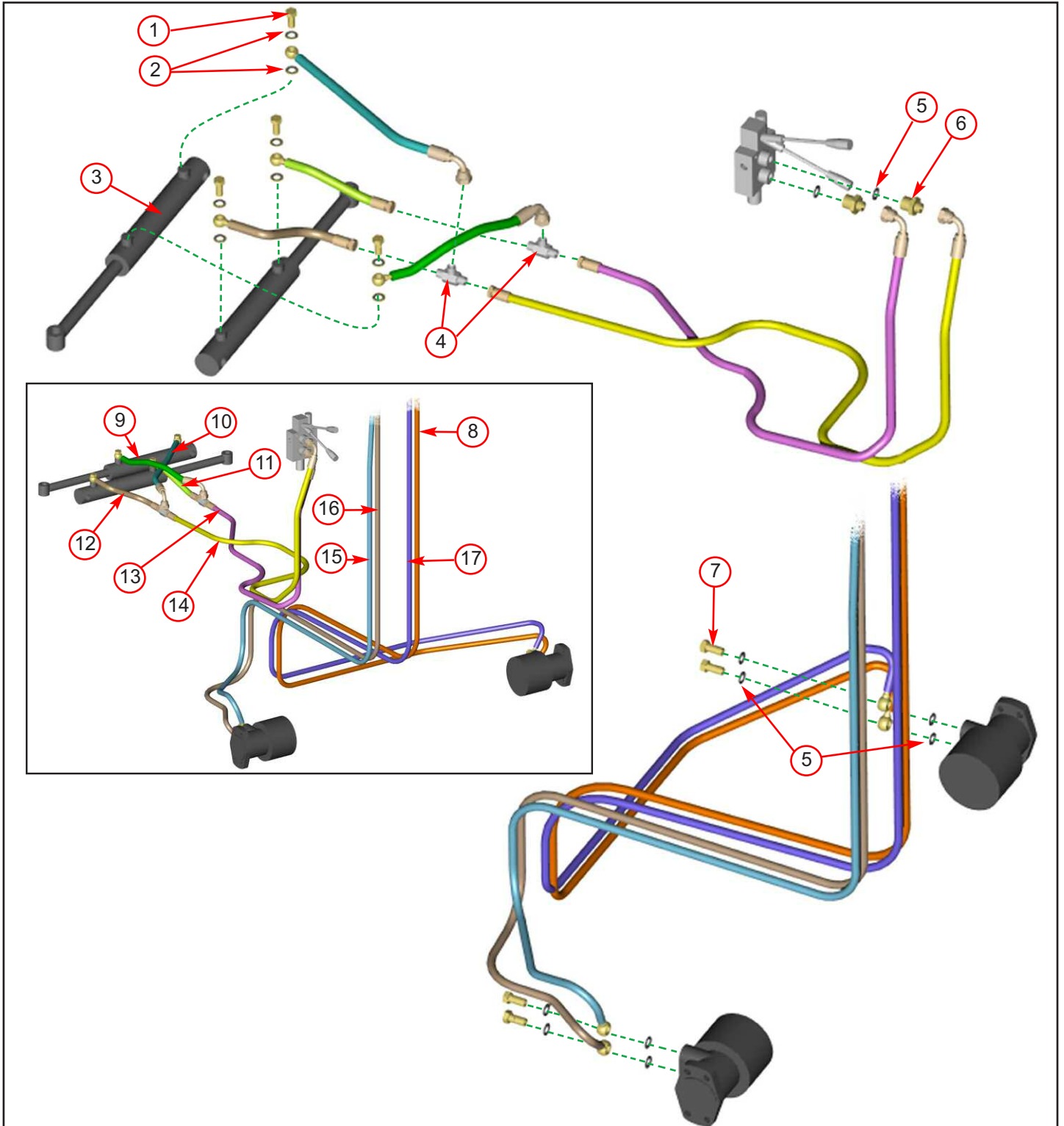

Item	Part No	Part Name	Q'ty	Item	Part No	Part Name	Q'ty
1	4059	1/4" Banjo Bolt	4	10	4031	1/4" Hose, LH track extend	1
2	0395	1/4" Dowty Washer	8	11	3080	1/4" Hose, RH track retract	1
3	4046	Hydraulic Cylinders	2	12	4032	1/4" Hose, RH track extend	1
4	4058	1/4" Tee Adapter	2	13	3083	1/4" Hose, trk extend feed	1
5	0396	3/8" Dowty Washer	10	14	3082	1/4" Hose, trk retract feed - valve	1
6	0033	1/4" - 3/8" Adapter	2	15	3088	3/8" Hose, LH upper trk motor - valve	1
7	4060	3/8" Banjo Bolt	2	16	3089	3/8" Hose, LH lower trk motor - valve	1
8	3086	3/8" Hose, RH lower trk motor - valve	1	17	3087	3/8" Hose, RH upper trk motor - valve	1
9	3081	1/4" Hose, LH track retract	1				

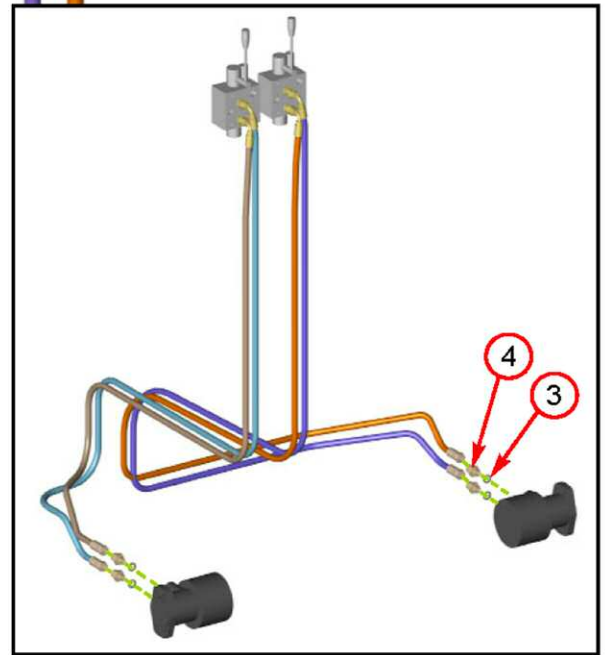
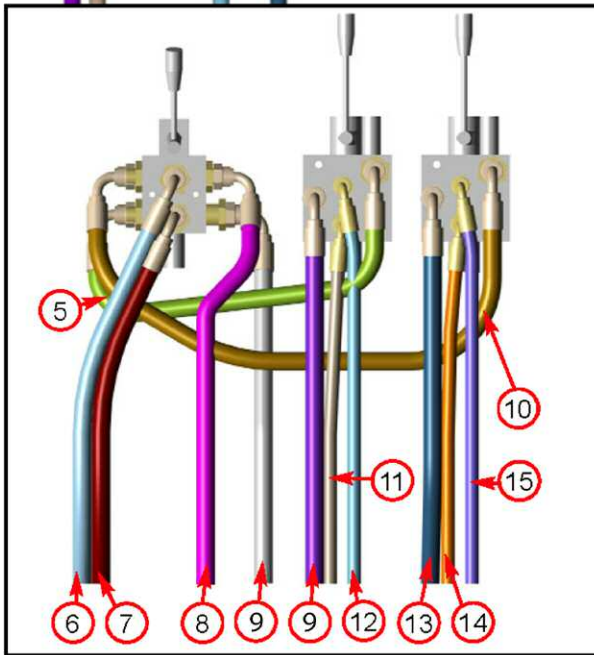
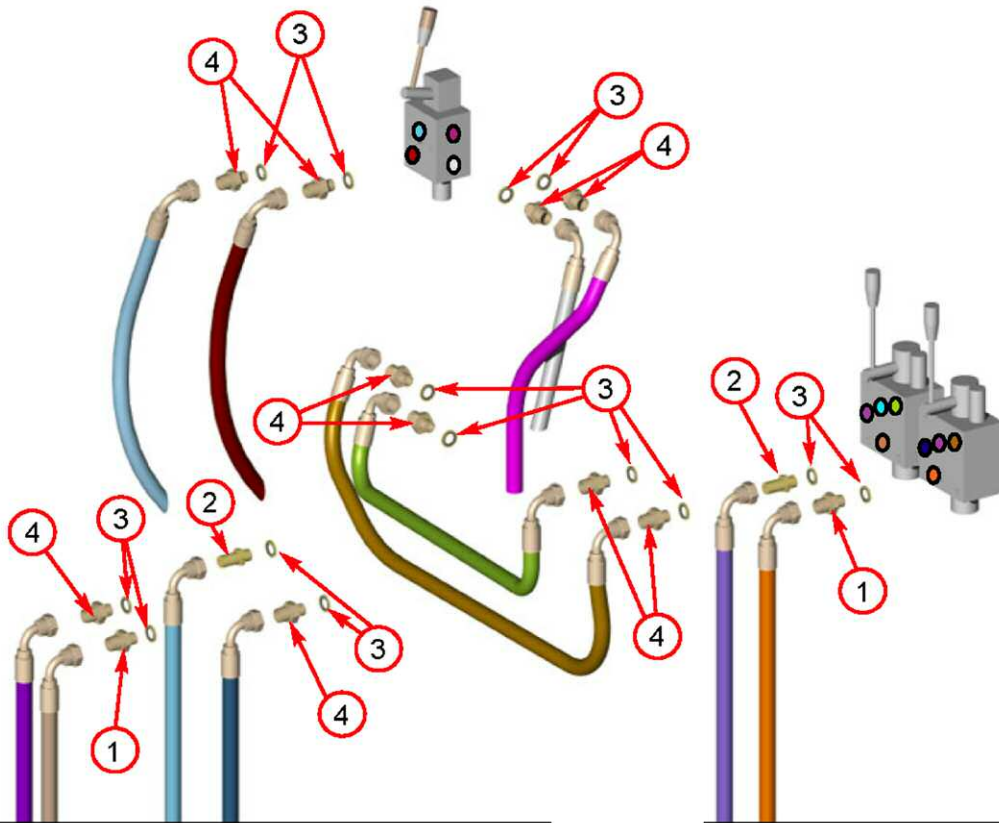

Item	Part No	Part Name	Q'ty
1	0161	3/8" - 3/8" Adapter	2
2	0212	1/2" Bulk Head Adapter	2
3	0396	3/8" Dowty Washer	18
4	0026	3/8" - 1/2" Adapter	14
5	3095	1/2" Hose, 6-way to prop. valve	1
6	4000	1/2" Hose to pump rear connection	1
7	3099	1/2" Hose to pump front	1
8	4240	1/2" Hose to DCV port 'P'	1

Item	Part No	Part Name	Q'ty
9	P*1190	1/2" Hose to manifold rear	2
10	3096	1/2" Hose, 6-way to prop. valve	1
11	P*1185	1/2" Hose to bottom of track motor	1
12	P*1186	1/2" Hose to top of track motor	1
13	P*1189	3/8" Hose to manifold	1
14	P*1183	1/2" Hose to bottom of track motor	1
15	P*1184	1/2" Hose to top of track motor	1

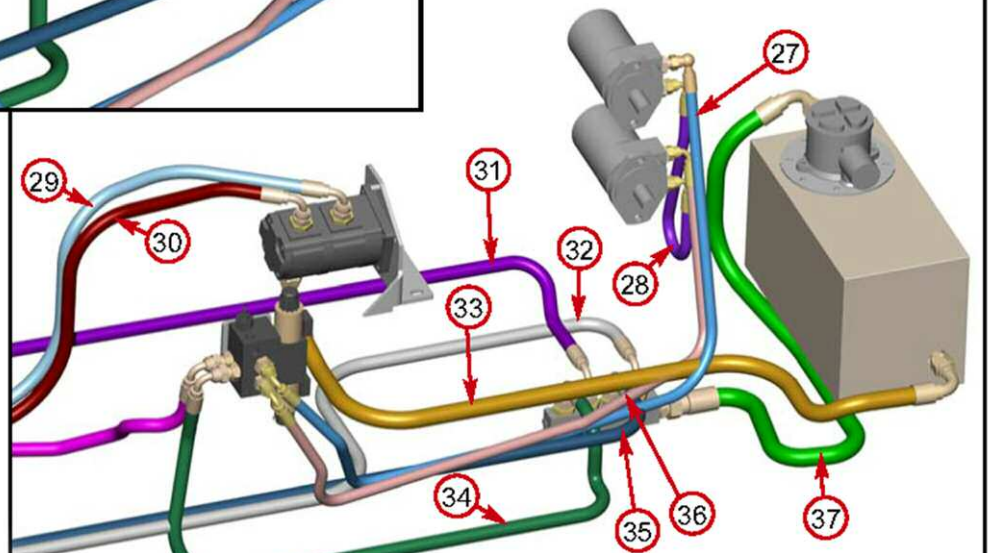
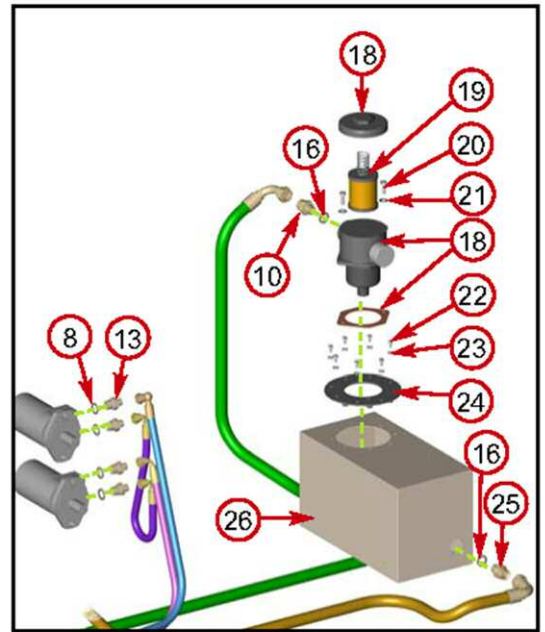
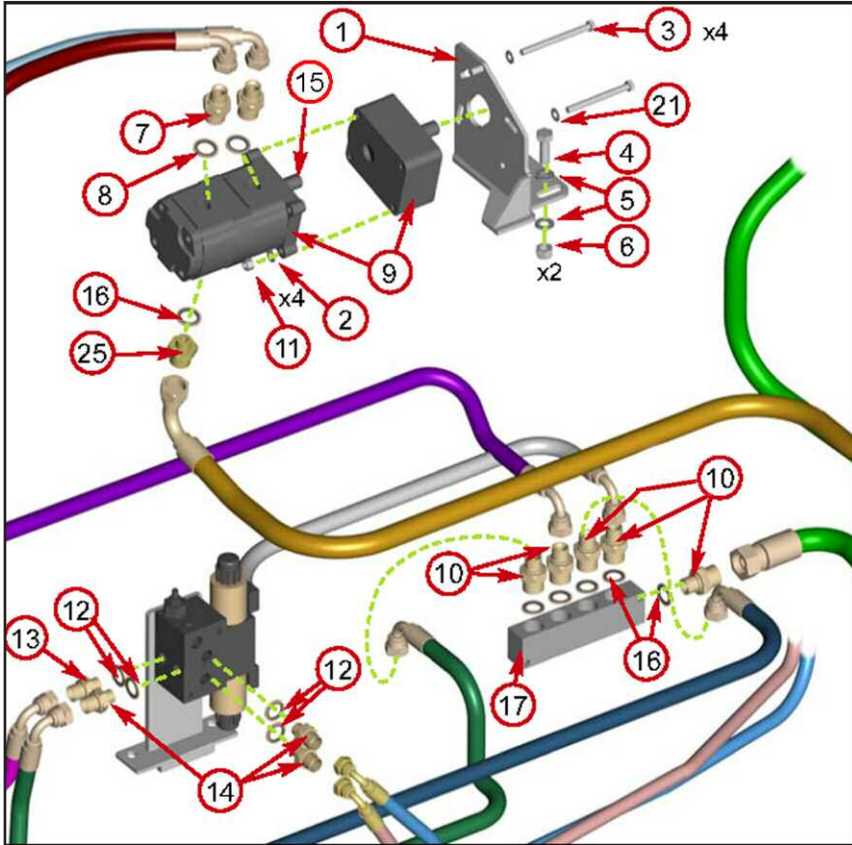

Item	Part No	Part Name	Q'ty
1	1913FS	Pump Bracket	1
2	0711	M8 A Washer	4
3	2988	M8/90 Bolt	4
4	0429	M12/35 Bolt	2
5	0702	M12 A Washer	4
6	0479	M12 P Nyloc Nut	2
7	0027	1/2" - 1/2" Adapter	2
8	0398	1/2" Dowty Seal	6
9	17344	Hydraulic Pump	1
10	0028	1/2" - 3/4" Adapter	6
11	0479	M8 P Nyloc Nut	4
12	0396	3/8" Dowty Seal	4
13	0026	3/8" - 1/2" Adapter	5
14	0161	3/8" - 3/8" Adapter	3
15	18508	Spline for pump	1
16	0152	3/4" Dowty Seal	8
17	1839MA	Manifold	1

Item	Part No	Part Name	Q'ty
20	0350	M8/25 Bolt	2
21	0712	M8 C Washer	6
22	1658	M6/12 Bolt	8
23	0709	M6 C Washer	8
24	1702FS	Tank Top Plate	1
25	2694	3/4" - 1" Adapter	2
26	1703	Hydraulic Tank	1
27	17309	3/8" Hose, DCV to upper motor	1
28	3092	3/8" Hose, motor to motor	1
29	4000	1/2" Hose, pump rear to 6-way valve	1
30	3099	1/2" Hose, pump front to 6-way valve	1
31	3091	3/8" Hose, manifold to LH valve	1
32	4302	1/2" Hose, manifold to 4-port valve	1
33	P*1191	1" Hose, tank to pump front	1
34	P*1188	3/8" Hose, manifold to DCV	1
35	3090	3/8" Hose, manifold to RH valve	1
36	3094	3/8" Hose, DCV to lower motor	1
37	P*1187	1/2" Hose, manifold to hyd filter	1

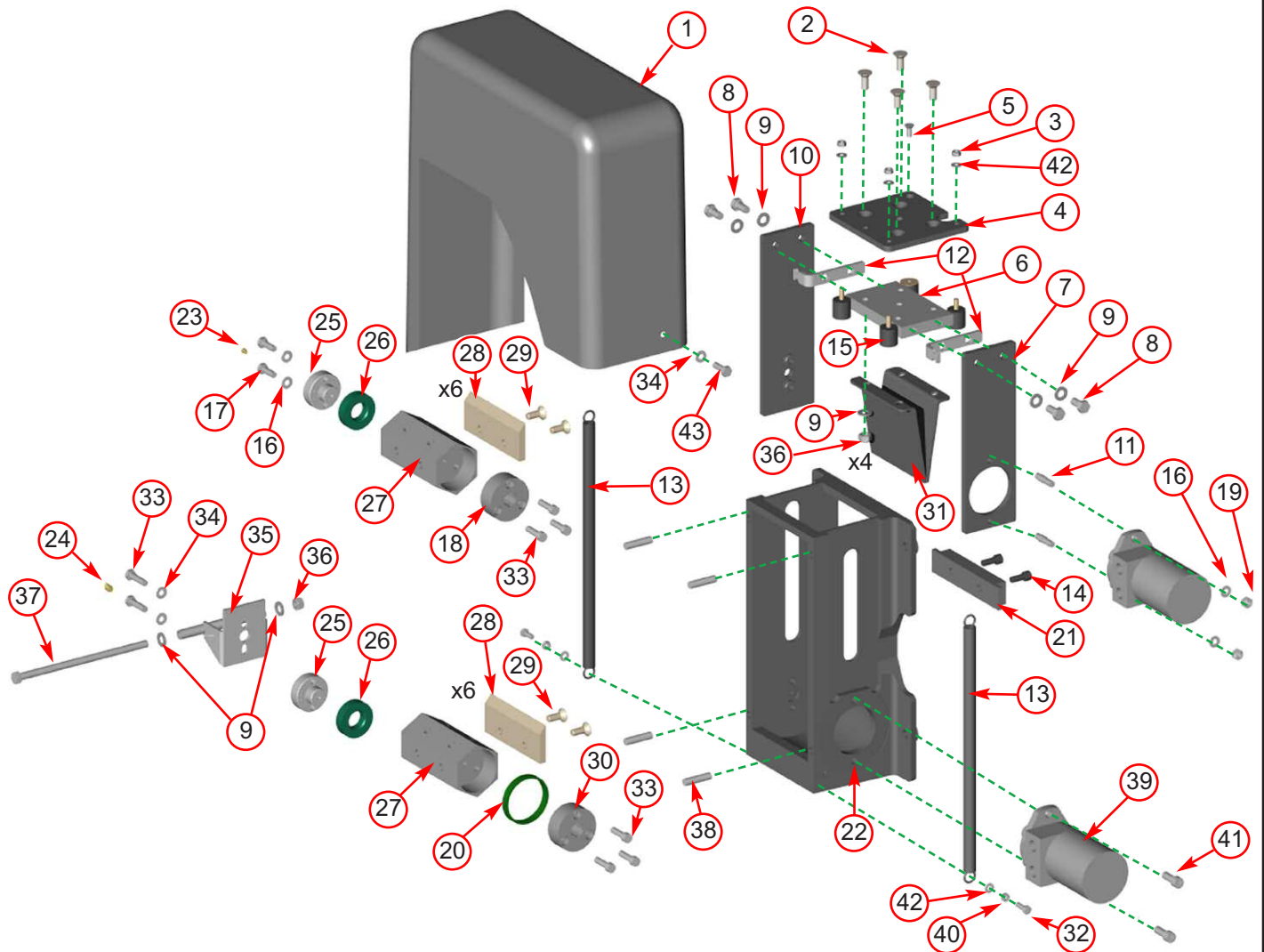

Item	Part No	Part Name	Q'ty
1	0672	Rollerbox Cover	1
2	18316	M12/50 Csk Bolt	4
3	0481	M8 T Nyloc Nut	3
4	18027M	Plate Top Damper Carrier	1
5	0348	M8/20 Csk Socket	1
6	1962FMS	Block Top Damped	1
7	18024M	Drive Side Plate	1
8	0429	M12/35 Bolt	4
9	0702	M12 A Washer	10
10	18025	Non Drive Side Plate	1
11	1162	Motor Studs	2
12	18028FS	Bracket Spring Hanger	2
13	18070	Roller Box Spring	2
14	0305	M10/25 Caphead	2
15	1768	AV Mount 30x30	4
16	0701	M10 A Washer	2
17	0382	M10/30 Bolt	4
18	1361M	Drive Spline	1
19	4345	M10 P Nyloc Nut	2
20	2757	Bush Bearing Spline	1
21	0103MH	Anvil	1
22	0228M	Roller Box	1

Item	Part No	Part Name	Q'ty
23	0985	Straight Grease Nipple	1
24	0986	45° Grease Nipple	1
25	0055	Bearing Boss	2
26	0788	Plastic Bush	2
27	1362M	Roller Body	2
28	0325M	Roller Blade	12
29	0428	M12/30 Csk Soc.	24
30	4100M	Spline 6B Retro Bottom	1
31	4013	Rotor Guard	1
32	0350	M8/25 Bolt	2
33	4068	M10/40 Cap Head Bolt	8
34	0839	M10 C Washer	3
35	0534FS	Cover Bracket	1
36	0045	M12 T Nyloc Nut	5
37	0319	M12/220 Bolt	1
38	0356	Funnel Studs M12/50	4
39	2982B	Motor	2
40	0476	M8 Plain Nut	2
41	1985	M12/30 Caphead	2
42	0711	M8 A Washer	5
43	0360	M10/25 Bolt	1

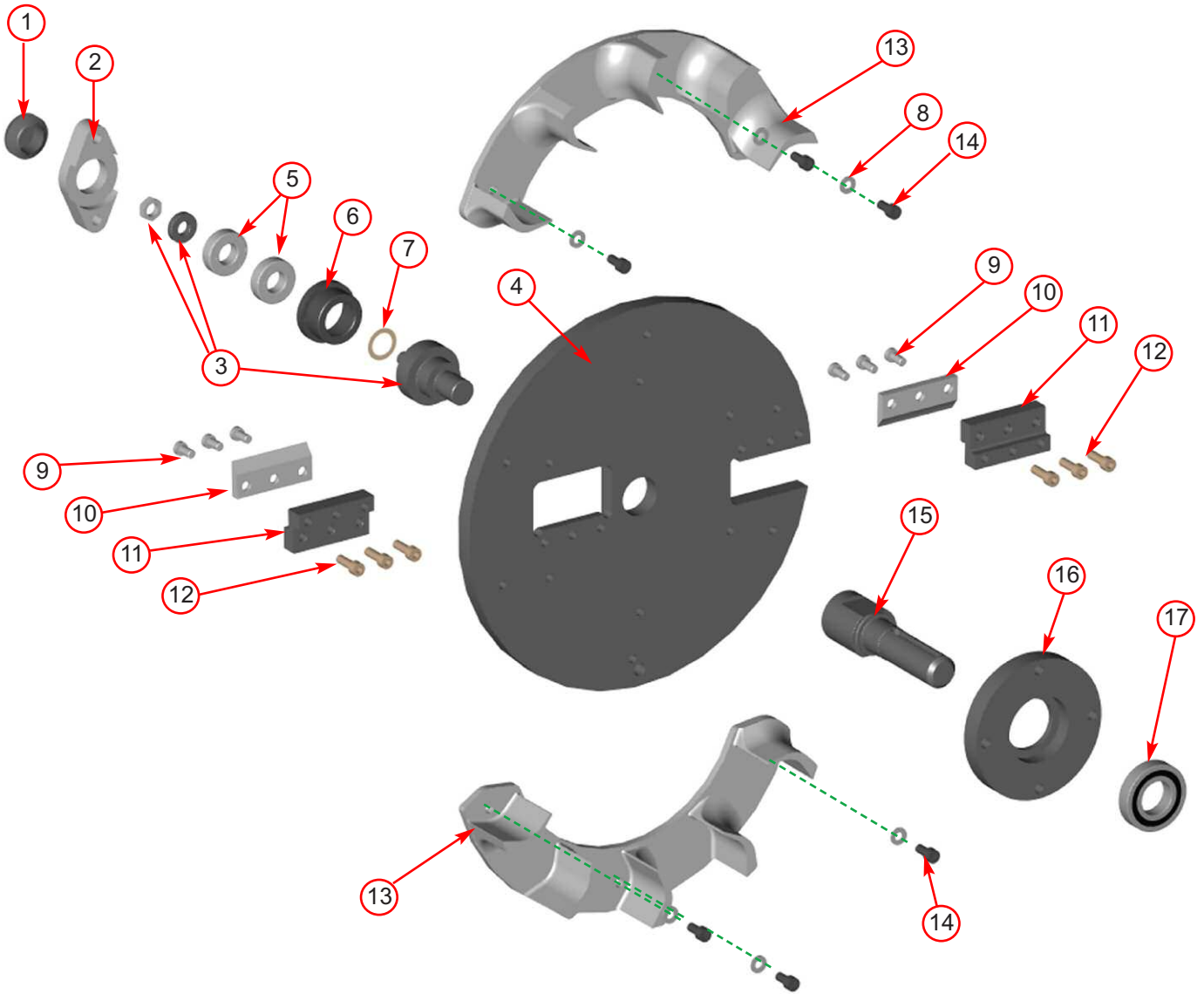

Item	Part No	Part Name	Q'ty
1	0959	Plastic Cap	1
2	0884MS	Bearing Housing Front	1
3	18479K	Rotor Nose Shaft Kit	1
4	0880M	Rotor	1
5	0491	Bearing 6205	2
6	0883MCB	Bearing Cup	1
7	0796	20 Thou Shim	As Req'd
8	0701	M10 A Washer	6
9	0900	M10/20 Star Cap Screw	6

Item	Part No	Part Name	Q'ty
10	083MH	Cutter Blade 4"	2
11	18275M	Blade Pocket	2
12	0386	M10/30 Cap Screw	6
13	1571	Fan Section	2
14	0386	M10/30 Caphead	6
15	18912M	Rear Shaft	1
16	4063MCB	Bearing Housing Rear	1
17	0495	Bearing 6208	1

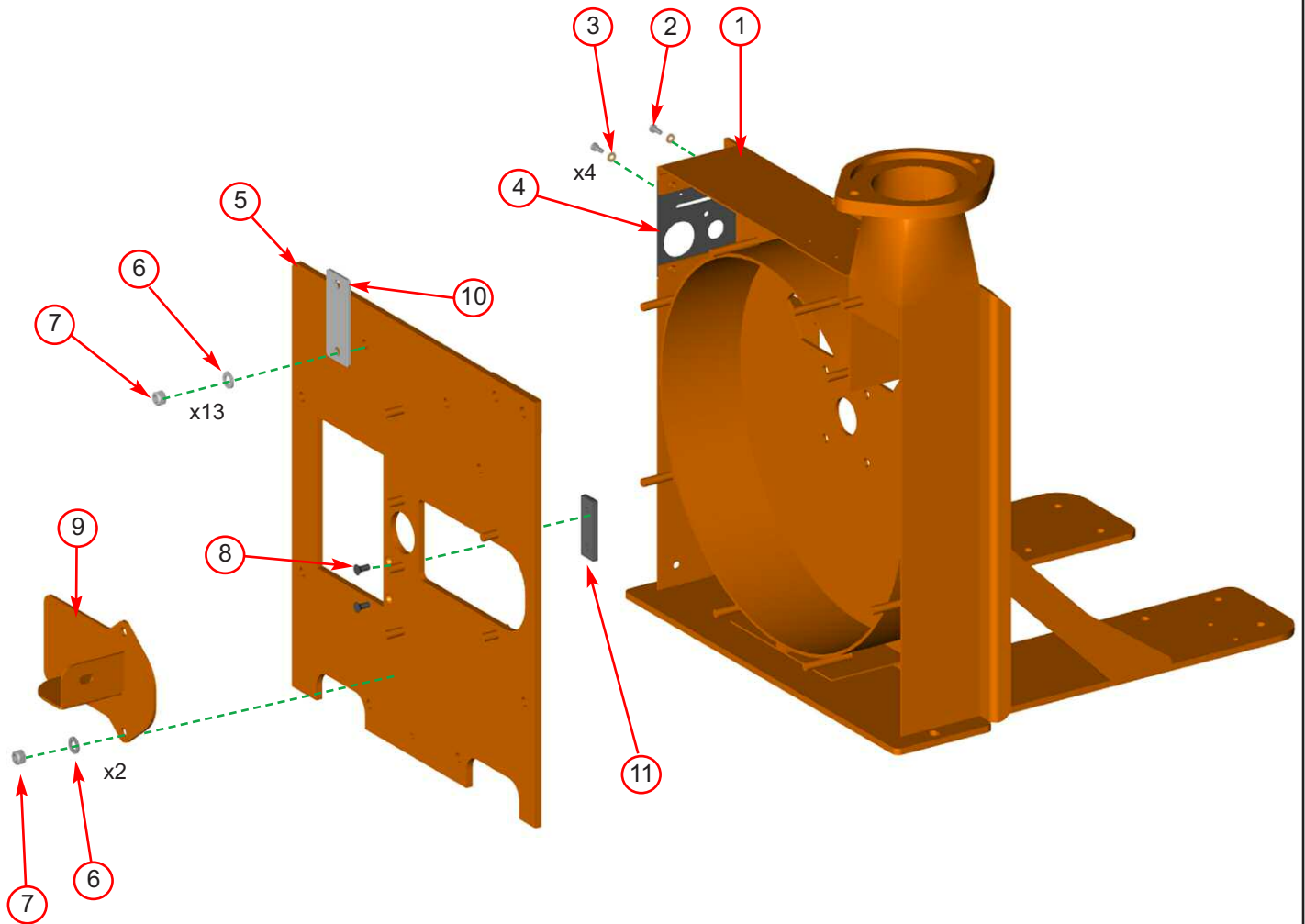

Item	Part No	Part Name	Q'ty	Item	Part No	Part Name	Q'ty
1	18436FO	Rotor Housing	1	7	0045	M12 T Nyloc Nut	15
2	0438	M6/16 Pozi Pan	4	8	0355	M8/16 C/Sunk Bolt	2
3	0709	M6 C Washer	4	9	1268FO	Access Cover	1
4	1758S	Control Panel	1	10	18023PS	Guard Stand-Off Plate	1
5	1267FO	Front Plate	1	11	0101MH	Anvil Vertical	1
6	0702	M12 A Washer	15				



TIMBERWOLF V-BELT TENSIONING DATA TABLE

METHOD:

1. SET THE DEFLECTION DISTANCE ON THE LOWER SCALE OF THE TENSION GAUGE SO THAT THE UNDERSIDE OF THE 'O'-RING EQUALS THE 'h' VALUE GIVEN IN THE TABLE BELOW
2. ENSURE THAT THE DEFLECTION FORCE SCALE IS ZERO'D BY PUSHING THE UPPER 'O'-RING ALL THE WAY DOWN
3. PLACE THE TENSION GAUGE IN THE CENTRE OF THE BELT SPAN AS SHOWN IN THE DIAGRAM LEFT
4. PRESS DOWNWARDS ON THE RUBBER BUFFER, DEFLECTING THE BELT UNTIL THE UNDERSIDE OF THE LOWER O-RING IS LEVEL WITH THE BELT BEHIND (USE A STRAIGHT EDGE IF THERE IS ONLY 1 BELT)
5. TAKE THE READING FROM THE DEFLECTION SCALE OF THE TENSION METER (READ AT THE LOWER EDGE OF THE 'O'-RING) & COMPARE THIS VALUE WITH THAT GIVEN IN THE TABLE BELOW
6. TIGHTEN OR LOOSEN BELTS AS REQUIRED FOLLOWING PROCEDURE GIVEN IN THE OPERATOR'S MANUAL

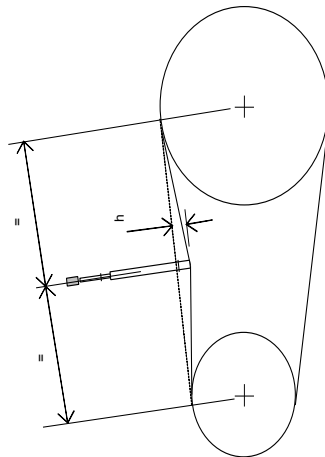

TIPS ON BELT TIGHTENING:

- A) THERE WILL NORMALLY BE A RAPID DROP IN TENSION DURING THE RUN-IN PERIOD FOR NEW BELTS. WHEN NEW BELTS ARE FITTED, CHECK THE TENSION EVERY 2-3 HOURS & ADJUST UNTIL THE TENSION REMAINS CONSTANT
- B) THE BEST TENSION FOR V-BELT DRIVES IS THE LOWEST TENSION AT WHICH THE BELTS DO NOT SLIP OR RATCHET UNDER THE HIGHEST LOAD CONDITION
- C) TOO MUCH TENSION SHORTENS BELT & BEARING LIFE
- D) TOO LITTLE TENSION WILL AFFECT THE PERFORMANCE OF YOUR MACHINE ESPECIALLY IN RESPECT OF NO-STRESS DEVICES
- E) ENSURE THAT BELT DRIVES ARE KEPT FREE OF ANY FOREIGN MATERIALS
- F) IF A BELT SLIPS - TIGHTEN IT!

TENSION GAUGES ARE AVAILABLE FROM TIMBERWOLF SPARES, QUOTING PART No. 18091

TW MODEL No.:		13/75G	18/100G	125PH	150DHB	150VTR	190TDHB/ 230DHB	190TFTR	190TVGTR	350DHB(i)	240TDHB(i)	PTO100	PTO150	S426 SHREDDER	S426FTR SHREDDER	PTO S426 SHREDDER	SX200 - ALL MODELS
Belt Mfr / Type		Gates Super HC-MIN	Gates Super HC-MIN	Gates Super HC-MIN	Gates Super HC-MIN	Gates Super HC-MIN	Gates Super HC-MIN	Gates Super HC-MIN	Gates Super HC-MIN	Gates Super HC-MIN	Gates Super HC-MIN	Gates Super HC-MIN	Gates Super HC-MIN	Gates Super HC-MIN	Gates Super HC-MIN	Gates Super HC-MIN	Gates Super HC-MIN
Belt Pitch Designation		SPA	SPA	SPA	SPA	SPA	SPA	SPA	SPA	SPA	SPA	SPA	SPA	SPA	SPA	SPA	SPA
Belt Length		900.0	1060.0	1060.0	1060.0	1060.0	1232.0	1232.0	1232.0	2530.0	1757.0	900.0	900.0	2120.0	2120.0	1700.0	1272.0
Belt deflection	= h	4.0	4.0	3.5	4.0	4.0	4.0	4.0	4.0	8.0	4.0	4.0	4.0	8.0	8.0	6.0	6.0
Force reading (Kgf)	New belt	3.4 - 3.6	3.1 - 3.3	3.3 - 3.6	4.3 - 4.5	4.3 - 4.5	3.9 - 4.1	3.9 - 4.1	3.9 - 4.1	3.3 - 3.6	3.7 - 4.0	3.3 - 3.5	3.8 - 4.0	3.3 - 3.5*	3.3 - 3.5	6.5 - 6.9	1.9 - 2.1
	Used belt	3.0 - 3.2	2.8 - 3.0	2.8 - 3.1	3.7 - 4.0	3.7 - 4.0	3.4 - 3.6	3.4 - 3.6	3.4 - 3.6	2.9 - 3.1	3.2 - 3.4	2.9 - 3.0	3.3 - 3.5	2.9 - 3.1*	2.9 - 3.1	5.6 - 6.0	1.7 - 1.8
Belt Mfr / Type		N/A	N/A	Gates Super HC-MIN	N/A	Gates Super HC-MIN	N/A	Gates Super HC-MIN	Gates Super HC-MIN	N/A	N/A	N/A	Gates Super HC-MIN	N/A	Gates Super HC-MIN	N/A	N/A
Belt Pitch Designation				SPA		SPA		SPA	SPA				SPA		SPA		
Belt Length				950.0		900.0		925.0	950.0				925.0		1060.0		
Belt deflection	= h			4.0		4.0		4.0	4.0				4.0		4.0		
Force reading (Kgf)	New belt			1.9 - 2.0		2.3 - 2.4		2.3 - 2.4	2.3 - 2.4				2.0 - 2.2		2.7 - 2.9		
	Used belt			1.7 - 1.8		2.0 - 2.1		2.0 - 2.2	2.0 - 2.2				1.8 - 2.0		2.3 - 2.5		





Timberwolf Wood Chippers & Shredders

Tomo Industrial Estate, Stowmarket, Suffolk IP14 5AY

T: 0845 686 0137 E: info@timberwolf-uk.com W: timberwolf-uk.com

